

A decorative graphic in the bottom left corner consisting of several overlapping orange circles and arcs of varying sizes.

PLUNGER FLOW CONTROL VALVE

PLUNGER FLOW CONTROL VALVE



The plunger flow control valve is mainly designed for regulating flow rate and pressure in water pipelines. This regulation is achieved by the axial movement of a plunger, operated by a shaft-rod-crank mechanism.

The plunger is positioned in the center of the valve, in a chamber specially shaped to protect it from the water flow and avoid noise and cavitation damage, while also ensuring vibrations-free operation.

The water flow is channelled through a ring-shaped chamber around the central body of the valve. The cross section of this chamber diminishes constantly from the inlet to the outlet, causing the flow speed to rise and the pressure to drop.

This ideal geometric shape protects the pipe from cavitation bubbles, which are directed towards the center of the down-stream outlet flange.

A perfect balance between the upstream and downstream chambers allows the plunger valve to be operated under low torque levels. The operating mechanism consists of a link, shaft, and connecting rod made of stainless steel. All the moving parts are supported by marine bronze bushings.

The plunger's sliding surface is entirely in stainless steel and is guided by sliding blocks which ensure stability in all operating conditions. The sliding blocks are screwed to the valve body for very easy maintenance.

A stainless steel seating ring is screwed onto the valve body. It is designed to ensure a perfect seal and easy maintenance of the interior valve components.

The seals are made of polyurethane rubber, with the main seal inserted directly into the top of the piston and the lip seal, with a special anti-extrusion profile, inserted into a matching seat formed in the valve body.

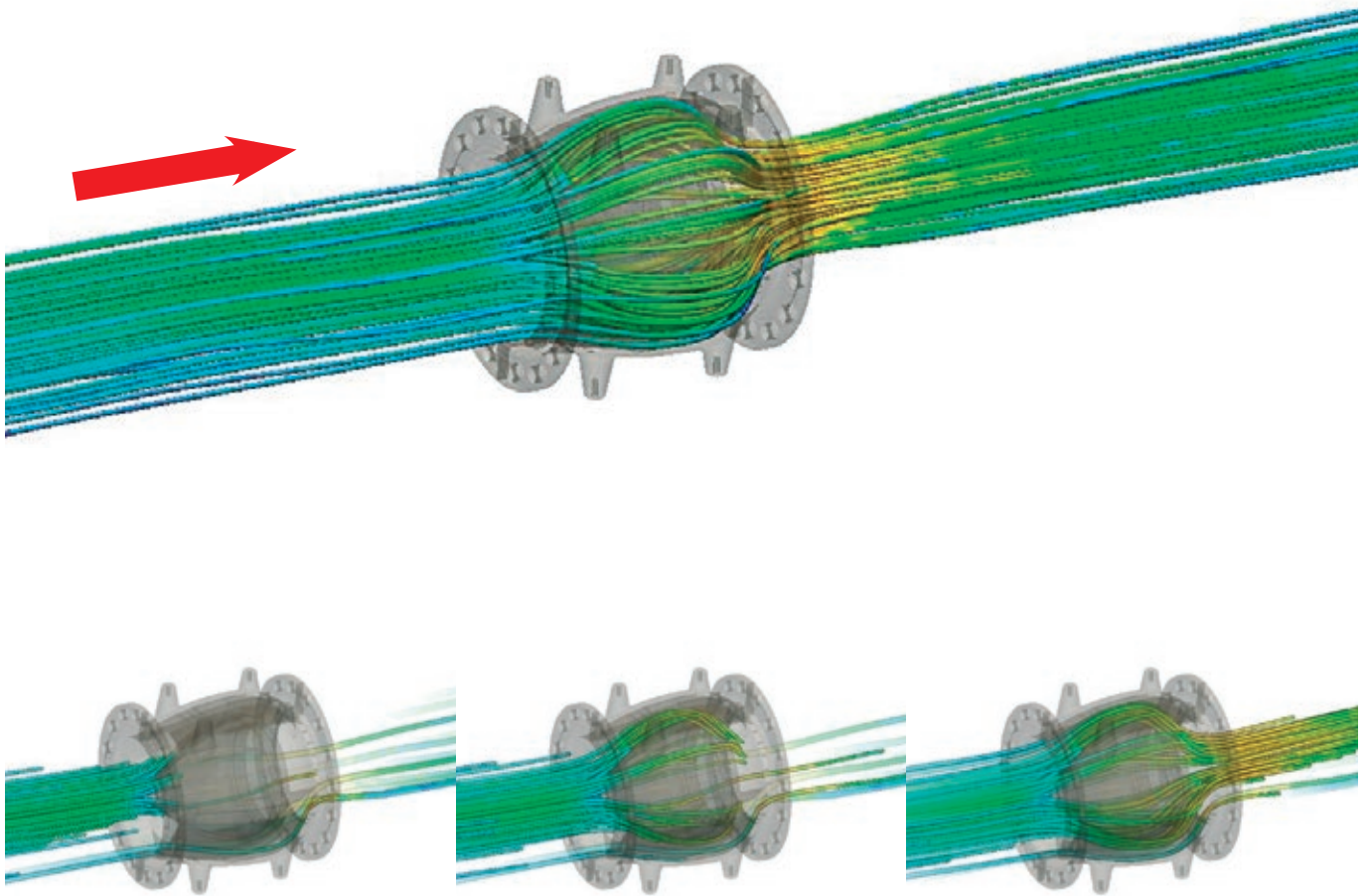

The special design directs the fluid towards the axis of the valve where the outflow collides, dissipating energy and protecting the walls of the down-stream pipe.

F560 • PLUNGER FLOW CONTROL VALVE

DN80 - DN150

DESIGN FEATURES

- Hydraulic test according to EN 1074-5 (\leq PN25) - EN 12266 (\geq PN40);
- Compliant with EN 1074-5 (PN10 - PN16 - PN25);
- The parts in contact with the fluid comply with Ministerial Decree 174 of 6/04/2004, suitable for use with drinking water and WRAS certified;
- One-piece body with annual section made of ductile cast iron type EN GJS 400-15 EN 1563 (GS 400-15);
- Face to face dimension according to EN 558 Series 15 (if not differently indicated);
- Flange dimensions according to EN 1092-2;
- All screws, washers, and nuts made of stainless steel A2-70 EN ISO 3506-1 (interior);
- Pressure-balanced piston movable with minimal torque made of stainless steel 1.4301 EN 10088-3 (AISI 304) or 1.4306 EN 10088-3 (AISI 304L);
- Seating box in 1.4408+AT EN 10283 (AISI 316);
- Seal retaining ring made of 1.4301 EN 10088-3 (AISI 304);
- Rod-link mechanism:
 - ★ link made of 1.4028 EN 10088-3 (AISI 420B);
 - ★ expulsion-safe shaft made of 1.4028 EN 10088-3 (AISI 420B);
 - ★ connecting rod made of 1.4301 EN 10088-3 (AISI 304);
- All rotating parts of the rod-link mechanism are supported by solid maintenance-free bronze bearings;
- Main seal protected from the water stream, made of polyurethane elastomer N-PU;
- Piston seal obtained with a low friction lip-type seal made of polyurethane elastomer N-PU;
- Actuator coupling flange according to ISO 5211;
- Internal and external corrosion protection obtained with FBE (fusion bounded epoxy) coating, colour blue RAL 5015, thickness 300 μ m;

ACCESSORIES

- Depending on the operating conditions, dissipating cylinders made of 1.4301 EN 10088-3 (AISI 304) or 1.4306 EN 10088-3 (AISI 304L) can be supplied
- Depending on the operating conditions, an air-intake device made of stainless steel 1.4301 EN 10088-3 (AISI 304) can be supplied.

OPERATING LIMITS

- Operating temperature: (water temp.) min. +0°C (without freezing) max. + 70°C (continuous use) - +95°C (peak).
- Storage temperature: (Room temp.) min. - 20°C max. + 70°C.

HIGH CORROSION-RESISTANT MATERIALS

On request, some parts can be made in high corrosion-resistant materials:

- piston, seat ring, and seal retaining ring made of 1.4401 EN 10088-3 (AISI 316) or 1.4404 EN 10088-3 (AISI 316 L) stainless steel;
- rod-link mechanism made of 1.4462 EN 10088-3 DUPLEX 2205 stainless steel;
- screws, washers, and nuts made of A4-70 EN ISO 3506-1 stainless steel ;
- anticavitation cylinder made of 1.4401 EN 10088-3 (AISI 316) or 1.4404 EN 10088-3 (AISI 316L) stainless steel.

COMPONENTS AND MATERIALS

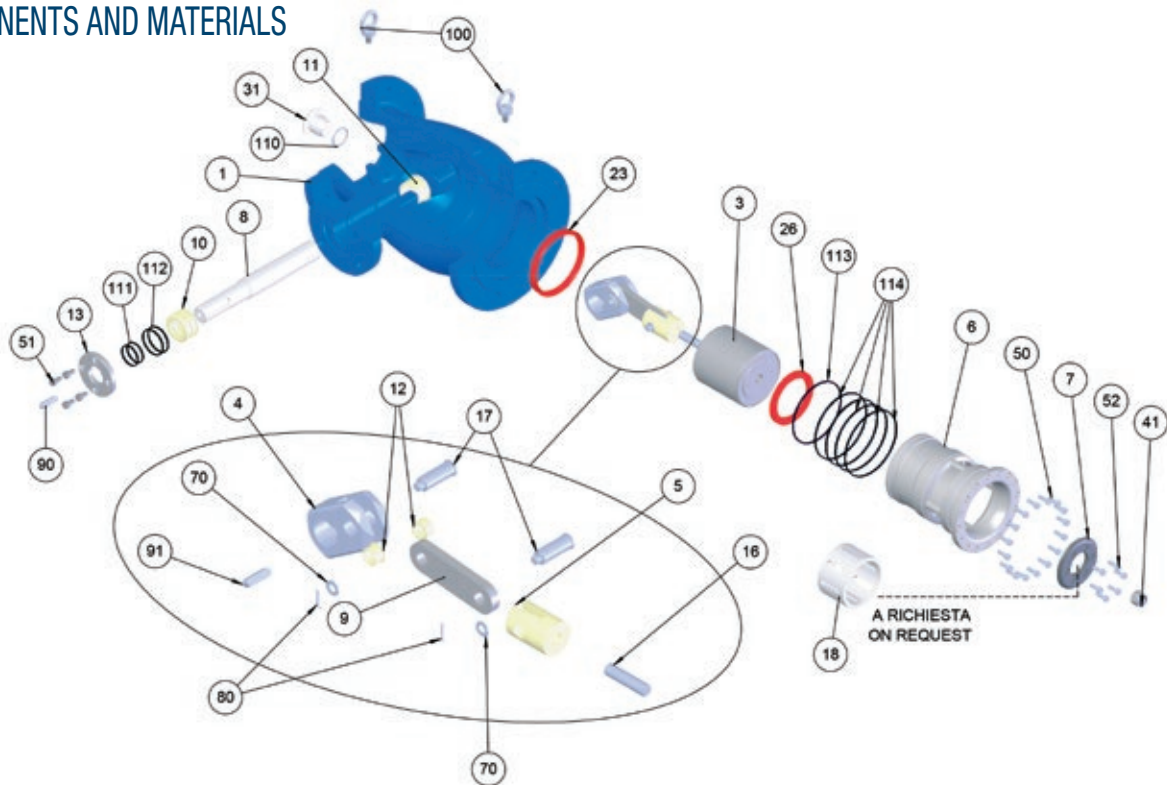

ITEM	COMPONENT	MATERIAL	NOTES
1	Body	EN-GJS 400-15 EN 1563 (GS 400 - 15)	Epoxy coating 300 µm
3	Obturator	1.4301 EN 10088-3 (AISI 304)	
4	Link	1.4028 EN 10088-3 QT850 (AISI 420 B)	
5	Fork	CC 333 G EN 1982 CuAl10Fe5Ni5-C	
6	Seating box	1.4408+AT EN 10283 (AISI 316)	
7	Seal retaining ring	1.4301 EN 10088-3 (AISI 304)	
8	Shaft	1.4028 EN 10088-3 QT850 (AISI 420 B)	
9	Piston rod	1.4301 EN 10088-3 (AISI 304)	
10	Outer bearing	CC 333 G EN 1982 CuAl10Fe5Ni5-C	
11	Inner bearing	CC 333 G EN 1982 CuAl10Fe5Ni5-C	
12	Link bearing	CC 333 G EN 1982 CuAl10Fe5Ni5-C	
13	Actuator coupling disk	1.4301 EN 10088-3 (AISI 304)	
16	Screw fork	1.4301 EN 10088-3 (AISI 304)	
17	Connecting pins	1.4028 EN 10088-3 QT850 (AISI 420 B)	
18	Dissipating cylinder (on request)	1.4301 EN 10088-3 (AISI 304) / 1.4306 EN 10088-3 (AISI 304L)	
23	Lip seal	N-PU polyurethane elastomer	
26	Main seal	N-PU polyurethane elastomer	
31	Nose cone	1.4301 EN 10088-3 (AISI 304)	
41	Nuts	1.4301 EN 10088-3 (AISI 304)	
50	Bolts	A2-70 EN ISO3506-1	
51	Bolts	A2-70 EN ISO3506-1	
52	Bolts	A2-70 EN ISO3506-1	
70	Washers	A2-70 EN ISO3506-1	
80	Cotter pins	A2-70 EN ISO3506-1	
90	Tongue	1.0511 EN 10083-2 + QT (C40B)	
91	Tongue (internal)	1.4028 EN 10088-3 QT850 (AISI 420 B)	
100	Eyebolt	Galvanized steel	
110 ÷ 114	O-ring	EPDM rubber	

DIMENSIONS AND WEIGHTS

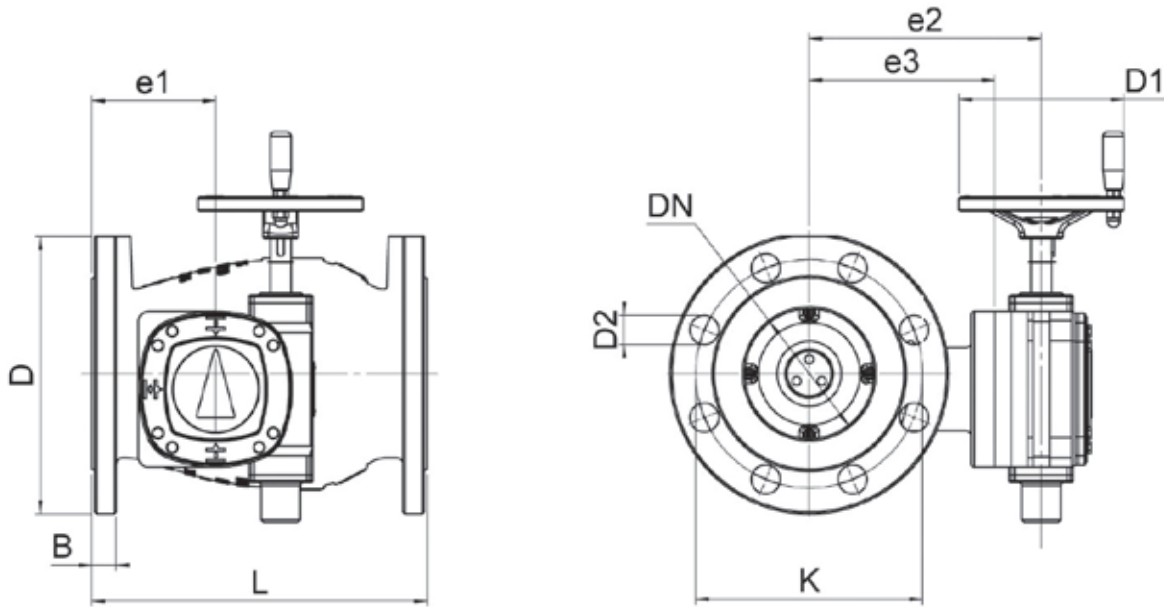

NUOVAL LINE

PN10

DN	80	100	125	150
D [mm]	200	220	250	285
D1 [mm]	175	175	200	200
D2 [mm]	19	19	19	23
B ³ [mm]	19	19	19	19
e1 [mm]	109	120	120	127
e2 [mm]	170	185	225	237
e3 [mm]	130	145	180	195
K [mm]	160	180	210	240
L ¹ [mm]	280	300	325	350
Holes [nr]	8	8	8	8
Weight ² [kg]	31	38	41	78

PN16

DN	80	100	125	150
D [mm]	200	220	250	285
D1 [mm]	175	175	200	200
D2 [mm]	19	19	19	23
B ³ [mm]	19	19	19	19
e1 [mm]	109	120	120	127
e2 [mm]	170	185	225	237
e3 [mm]	130	145	180	195
K [mm]	160	180	210	240
L ¹ [mm]	280	300	325	350
Holes [nr]	8	8	8	8
Weight ² [kg]	31	38	41	78

PN25

DN	80	100	125	150
D [mm]	200	235	270	300
D1 [mm]	175	175	200	200
D2 [mm]	19	23	28	28
B ³ [mm]	19	19	19	26
e1 [mm]	109	120	120	127
e2 [mm]	170	185	225	237
e3 [mm]	130	145	180	195
K [mm]	160	190	220	250
L ¹ [mm]	280	300	325	350
Holes [nr]	8	8	8	8
Weight ² [kg]	30,5	38	46	82

PN40

DN	80	100	125	150
D [mm]	200	235	270	300
D1 [mm]	175	200	200	200
D2 [mm]	19	23	28	28
B ³ [mm]	19	19	23,5	26
e1 [mm]	109	120	120	127
e2 [mm]	170	185	225	237
e3 [mm]	130	145	180	195
K [mm]	160	190	220	250
L ¹ [mm]	280	300	325	350
Holes [nr]	8	8	8	8
Weight ² [kg]	31	43	46	82

PN64

DN	80	100	125	150
D [mm]	215	250	295	345
D1 [mm]	175	200	200	200
D2 [mm]	23	28	31	34
B ³ [mm]	31	33	37	39
e1 [mm]	109	120	120	127
e2 [mm]	175	190	237	262
e3 [mm]	130	145	180	205
K [mm]	170	200	240	280
L ¹ [mm]	280	300	325	350
Holes [nr]	8	8	8	8
Weight ² [kg]	35	55	80	108

1: face to face dimension according to EN 558 series 15
 2: gearbox included

Inlet/outlet flange: PN10-16 seal surface type B (raised face), PN25-40-64 seal surface type A (flat)

F500 • PLUNGER FLOW CONTROL VALVE

DN200 - DN1400

DESIGN FEATURES

- Hydraulic test according to EN 1074-5 (\leq PN25) - EN 12266 (\geq PN40);
- Compliant with EN 1074-5 (PN10 - PN16 - PN25);
- The parts in contact with the fluid comply with Ministerial Decree 174 of 6/04/2004, suitable for use with drinking water and WRAS certified;
- One-piece body with annual section made of ductile cast iron:
 - ★ EN GJS 500-7 EN 1563 (GS 500-7) up to PN25 included;
 - ★ EN GJS 400-15 EN 1563 (GS 400-15) for $\text{PN} \geq 40$;
- Face to face dimension according to EN 558 Series 15 (if not differently indicated);
- Flange dimensions according to EN 1092-2 (PN40 $\text{DN} \geq 700$ excluded);
- All screws, washers, and nuts made of stainless steel A2-70 EN ISO3506-1 (interior);
- Pressure-balanced piston movable with minimal torque:
 - ★ from DN150 to DN1000 made of stainless steel 1.4301 EN 10088-3 (AISI 304) or 1.4306 EN 10088-3 (AISI 304L);
 - ★ from DN1200 to DN1400 made of stainless steel and FBE coated structural steel;
- Corrosion and friction resistant bronze-aluminum piston guides, screwed to the body for easy maintenance;
- Seat ring made of 1.4301 EN 10088-3 (AISI 304);
- Seal retaining ring made of 1.4301 EN 10088-3 (AISI 304);
- Rod-link mechanism:
 - ★ link:
 - ◇ from DN200 to DN700 made of 1.4028 EN 10088-3 (AISI 420B);
 - ◇ from DN800 to DN1400 made of FBE coated structural steel;
 - ★ expulsion-safe shaft made of 1.4028 EN 10088-3 (AISI 420B);
 - ★ connecting rod made of 1.4028 EN 10088-3 (AISI 420B);
- All rotating parts of the rod-link mechanism are supported by solid maintenance-free bronze bearings;
- Main seal protected from the water stream, made of polyurethane elastomer N-PU;
- Piston seal obtained with a low friction lip-type seal made of polyurethane elastomer N-PU;
- Actuator coupling flange according to ISO 5211;
- Internal and external corrosion protection with FBE coating (fusion bounded epoxy), blue colour RAL 5015, thickness 300 μm .

ACCESSORIES

- Depending on the operating conditions, dissipating cylinders made of 1.4301 EN 10088-3 (AISI 304) or 1.4306 EN 10088-3 (AISI 304L) can be supplied;
- Depending on the operating conditions, air-intake device made of FBE coated structural steel can be supplied.

OPERATING LIMITS

- Operating temperature: (water temp.) min. +0°C (without freezing) max. +70°C (continuous use) - +95°C (peak).
- Storage temperature: (Room temp.) min. -20°C max. +70°C.

HIGH CORROSION-RESISTANT MATERIALS

On request, some parts can be made in high corrosion-resistant materials:

- piston, seat ring, and seal retaining ring made of 1.4401 EN 10088-3 (AISI 316) or 1.4404 EN 10088-3 (AISI 316L) stainless steel;
- rod-link mechanism made of 1.4462 EN 10088-3 DUPLEX 2205 stainless steel;
- screws, washers, and nuts made of A4-70 EN ISO 3506-1 stainless steel;
- anticavitation cylinder made of 1.4401 EN 10088-3 (AISI 316) or 1.4404 EN 10088-3 (AISI 316L) stainless steel.

COMPONENTS AND MATERIALS

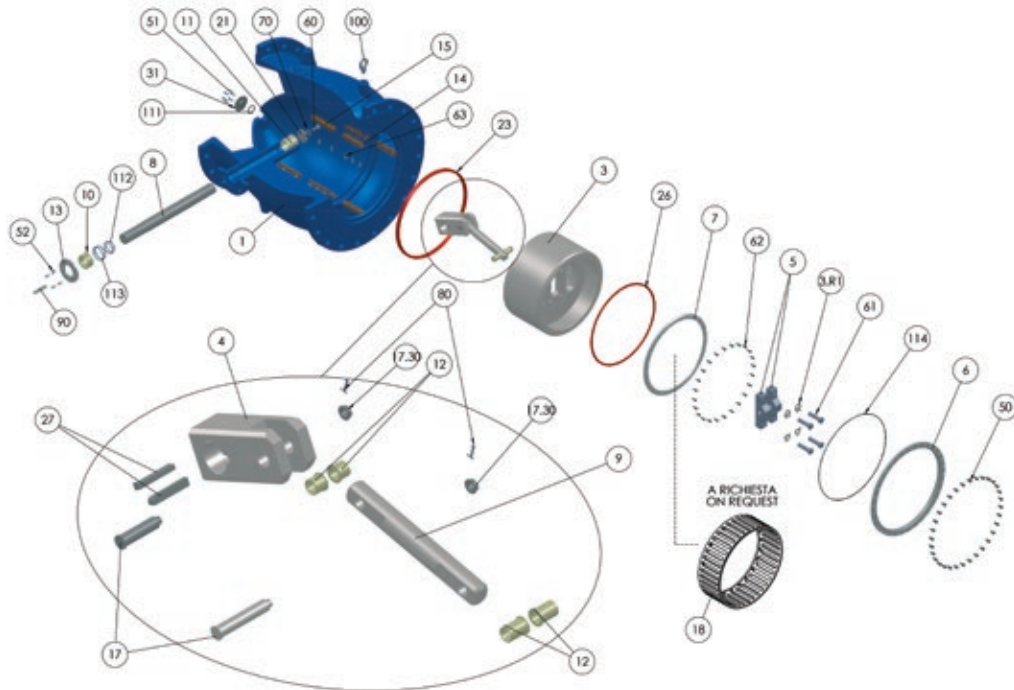

ITEM	COMPONENT	MATERIAL	NOTE
1	Body	EN-GJS 500 - 7 EN 1563 (GS 500 - 7)	Epoxy coating 300 µm
	Body (for PN ≥ 40)	EN-GJS 400 - 15 EN 1563 (GS 400 - 15)	Epoxy coating 300 µm
3	Obturator	1.4301 EN 10088-3 (AISI 304) / 1.4306 EN 10088-3 (AISI 304L)	
3.R1	Locking washer	1.4401 EN 10088-3 (AISI 316)	
4	Link (DN200 - DN700)	1.4028 EN 10088-3 (AISI 420 B)	
	Link (DN800 - DN1400)	Structural steel	Epoxy coating 300 µm
5	Fork (DN200 - DN300)	1.4028 EN 10088-3 (AISI 420 B)	
	Bracket-fork (DN350 - DN1400)	1.4028 EN 10088-3 (AISI 420 B) / 1.4462 EN 10088-3 (DUPLIX 2205)	
6	Seating ring	1.4301 EN 10088-3 (AISI 304)	
7	Seal retaining ring	1.4301 EN 10088-3 (AISI 304)	
8	Shaft	1.4028 EN 10088-3 (AISI 420 B)	
9	Connecting rod	1.4028 EN 10088-3 (AISI 420 B)	
10 / 11 / 12	Outer / Inner bearing / Link bearing	CC 333 G EN 1982 CuAl10Fe5Ni5-C (Bronze)	
13	Actuator coupling disk	1.4301 EN 10088-3 (AISI 304)	
14 / 15	Sliding blocks	CW 307 G M EN 12165 (Bronze)	
17	Connecting pins	1.4028 EN 10088-3 (AISI 420 B)	
17.30	Washer for connecting pins	1.4401 EN 10088-3 (AISI 316)	
18	Dissipating cylinder (on request)	1.4301 EN 10088-3 (AISI 304) / 1.4306 EN 10088-3 (AISI 304L)	
21	Stop washer	1.4301 EN 10088-3 (AISI 304)	
23	Lip Seal	N-PU polyurethane elastomer	
26	Main Seal	N-PU polyurethane elastomer	
27	Tongue (internal)	1.4028 EN 10088-3 (AISI 420 B)	
31	Nose cone (DN200 - DN800)	1.4301 EN 10088-3 (AISI 304)	
	Nose cone (DN900 - DN1400)	Polymer POM	
50/51/52/60 61/62/63	Screws	A2-70 EN ISO3506-1	
70	Locking washer	A2-70 EN ISO3506-1	
80	Cotter pins	A2-70 EN ISO3506-1	
90	Tongue	1.0511 EN 10083-2 + QT (C40B)	
10	Eyebolt	Galvanized steel	
110 - 114	O-Ring	EPDM	

NUOVAL LINE



DIMENSIONS AND WEIGHTS

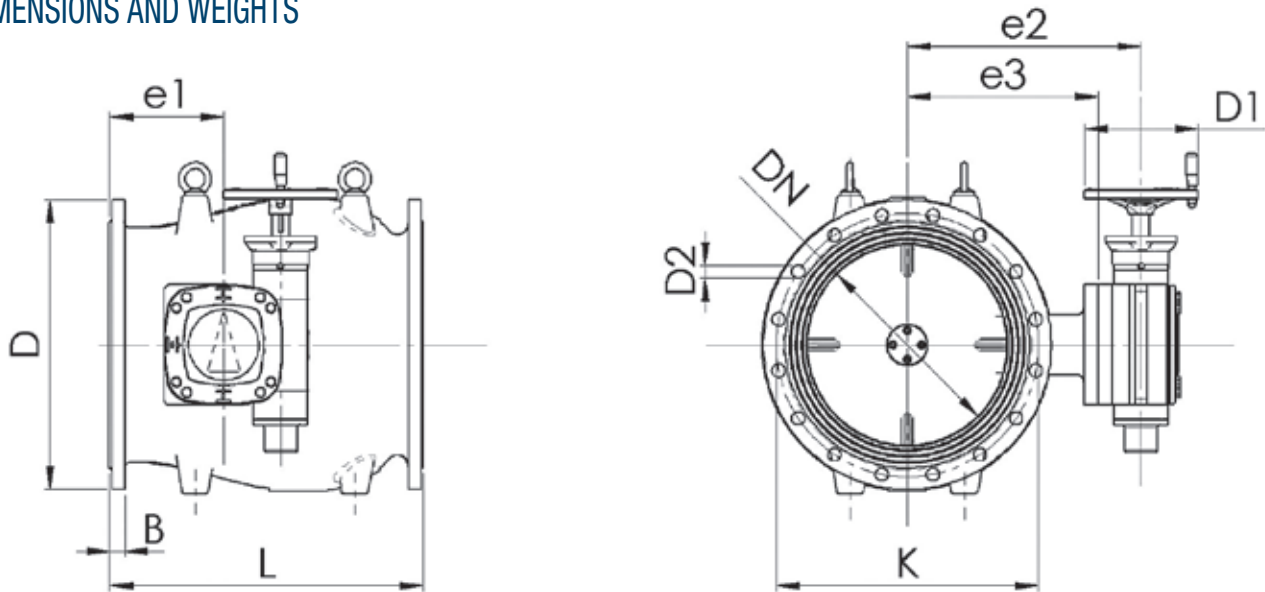

PN10

DN	200	250	300	350	400	450	500	600	700	800	900	1000	1200	1400
D [mm]	340	395	445	505	565	615	670	780	895	1015	1115	1230	1455	1675
D1 [mm]	200	200	200	250	250	250	250	250	250	250	250	250	250	250
D2 [mm]	23	23	23	23	28	28	28	31	31	34	34	37	41	44
B ³ [mm]	20	22	24,5	24,5	24,5	25,5	26,5	30	32,5	35	37,5	40	45	46
e1 [mm]	160	164	185	200	230	235	245	318	310	325	350	360	425	475
e2 [mm]	273	300	352	410	440	470	500	563	647	700	753	815	1015	1128
e3 [mm]	228	255	295	335	365	395	425	488	572	625	678	740	900	1013
K [mm]	295	350	400	460	515	565	620	725	840	950	1050	1160	1380	1590
L ¹ [mm]	400	450	500	550	600	650	700	800	900	1000	1100	1200	1400	1600
Holes [nr]	8	12	12	16	16	20	20	20	24	24	28	28	32	36
Weight ² [kg]	106	145	195	290	335	495	470	700	1000	1330	1725	2265	3530	5020

PN16

DN	200	250	300	350	400	450	500	600	700	800	900	1000	1200	1400
D [mm]	340	405	460	520	580	640	715	840	910	1025	1125	1255	1485	1685
D1 [mm]	200	200	200	250	250	250	250	250	250	250	250	250	250	250
D2 [mm]	23	28	28	28	31	31	34	37	37	41	41	44	50	50
B ³ [mm]	20	22	24,5	26,5	28	30	31,5	36	39,5	43	46,5	50	57	60
e1 [mm]	160	164	185	200	230	235	245	318	310	325	350	360	425	475
e2 [mm]	273	300	352	410	440	470	500	563	647	700	753	815	1015	1128
e3 [mm]	228	255	295	335	365	395	425	488	572	625	678	740	900	1013
K [mm]	295	355	410	470	525	585	650	770	840	950	1050	1170	1390	1590
L ¹ [mm]	400	450	500	550	600	650	700	800	900	1000	1100	1200	1400	1600
Holes [nr]	12	12	12	16	16	20	20	20	24	24	28	28	32	36
Weight ² [kg]	106	145	195	290	335	495	510	750	1005	1330	1770	2290	3575	5030

PN25

DN		200	250	300	350	400	450	500	600	700	800	900	1000
D	[mm]	360	425	485	555	620	670	730	845	960	1085	1185	1320
D1	[mm]	200	200	250	250	250	250	250	250	250	250	250	250
D2	[mm]	28	31	31	34	37	37	37	41	44	50	50	57
B ³	[mm]	22	24,5	27,5	30	32	34,5	36,5	42	46,5	51	55,5	60
e1	[mm]	160	164	185	200	230	235	245	318	310	325	350	360
e2	[mm]	273	300	370	410	440	470	500	563	682	735	778	840
e3	[mm]	228	255	295	335	365	395	425	488	607	660	703	725
K	[mm]	310	370	430	490	550	600	660	770	875	990	1090	1210
L ¹	[mm]	400	450	500	550	600	650	700	800	900	1000	1100	1200
Holes	[nr]	12	12	16	16	16	20	20	20	24	24	28	28
Weight ²	[kg]	113	152	248	324	404	501	593	768	1190	1575	2160	2850

PN40

DN		200	250	300	350	400	500	600	700	800	900	1000
D	[mm]	375	450	515	580	660	755	890	995	1140	1250	1360
D1	[mm]	250	250	250	250	250	250	250	315	315	400	400
D2	[mm]	31	34	34	37	41	44	50	48	56	56	56
B ³	[mm]	30	34,5	39,5	43,5	48	52	58	64	72	76	80
e1	[mm]	160	164	185	200	200	245	275	-	-	-	400
e2	[mm]	262	287	345	440	470	555	610	-	-	-	999
e3	[mm]	205	240	270	390	420	480	535	-	-	-	854
K	[mm]	320	385	450	510	585	670	795	900	1030	1140	1250
L ¹	[mm]	400	450	500	550	600	700	800	1000	1100	1200	1300
Holes	[nr]	12	12	16	16	16	20	20	24	24	28	28
Weight ²	[kg]	122	165	265	350	435	880	1020	1650	2300	3050	3950

PN64

DN		200	250	300	350	400
D	[mm]	415	470	530	600	670
D1	[mm]	250	250	250	250	250
D2	[mm]	37	37	37	41	44
B ³	[mm]	46	50	57	61	65
e1	[mm]	160	164	185	218	238
e2	[mm]	280	315	345	465	495
e3	[mm]	205	240	270	390	420
K	[mm]	345	400	460	525	585
L ¹	[mm]	400	450	500	585	636
Holes	[nr]	12	12	16	16	16
Weight ²	[kg]	150	195	285	490	640

- 1: Face to face dimension according to EN 558 series 15 (DN350 and DN400 PN64, DN700, DN800, DN900 and DN1000 PN40 excluded)
- 2: Gearbox included

Inlet/outlet flange: PN10-16-25 seal surface type B (raised face), PN40-64 seal surface type A (flat)

F550 • PLUNGER FLOW CONTROL VALVE

DN 1600 - DN 1800

DESIGN FEATURES

- Hydraulic test according to EN 1074-5 (\leq PN25) - EN 12266 (\geq PN40);
- Compliant with EN 1074-5 (PN10 - PN16 - PN25);
- Compliant with EN 1074-5;
- The parts in contact with the fluid comply with Ministerial Decree 174 of 6/04/2004, suitable for use with drinking water and WRAS certified;
- One-piece body with annual section made of ductile cast iron according to EN GJS 500-7 EN 1563 (GS 500-7);
- Flange dimensions according to EN 1092-2;
- All screws, washers, and nuts made of stainless steel A2-70 EN ISO 3506-1 (interior);
- Pressure-balanced piston movable with minimal torque made of stainless steel;
- Corrosion and friction resistant bronze aluminum piston guides, screwed to the body for easy maintenance;
- Seat ring made of 1.4301 EN 10088-3 (AISI 304);
- Seal retaining ring made of 1.4301 EN 10088-3 (AISI 304);
- Rod-link mechanism:
 - ★ link made of FBE coated structural steel;
 - ★ expulsion-safe shaft made of 1.4028 EN 10088-3 (AISI 420B);
 - ★ connecting rod made of 1.4028 EN 10088-3 (AISI 420B);
- All rotating parts of the rod-link mechanism are supported by solid maintenance-free bronze bearings;
- Main seal protected from the water stream, made of polyurethane elastomer N-PU;
- Piston seal obtained with a low friction lip-type seal made of polyurethane elastomer N-PU;
- Actuator coupling flange according to ISO 5211;
- Internal and external corrosion protection obtained with FBE (fusion bounded epoxy) coating, colour blue RAL 5015, Thickness 300 μ m;

ACCESSORIES

- Depending on the operating conditions, anticavitation cylinders made of 1.4301 EN 10088-3 (AISI 304) or 1.4306 EN 10088-3 (AISI 304L) can be supplied;
- Depending on the operating conditions, air-intake device made of FBE coated structural steel can be supplied.

OPERATING LIMITS

- Operating temperature: (water temp.) min. +0°C (without freezing) max. +70°C (continuous use) - +95°C (peak).
- Storage temperature: (Room temp.) min. -20°C max. +70°C.

HIGH CORROSION-RESISTANT MATERIALS

On request, some parts can be made in high corrosion-resistant materials:

- piston, seat ring, and seal retaining ring made of 1.4401 EN 10088-3 (AISI 316) or 1.4404 EN 10088-3 (AISI 316L) stainless steel;
- rod-link mechanism made of 1.4462 EN 10088-3 DUPLEX 2205 stainless steel;
- screws, washers, and nuts made of A4-70 EN ISO 3506-1 stainless steel ;
- anticavitation cylinder made of 1.4401 EN 10088-3 (AISI 316) or 1.4404 EN 10088-3 (AISI 316L) stainless steel.

COMPONENTS AND MATERIALS

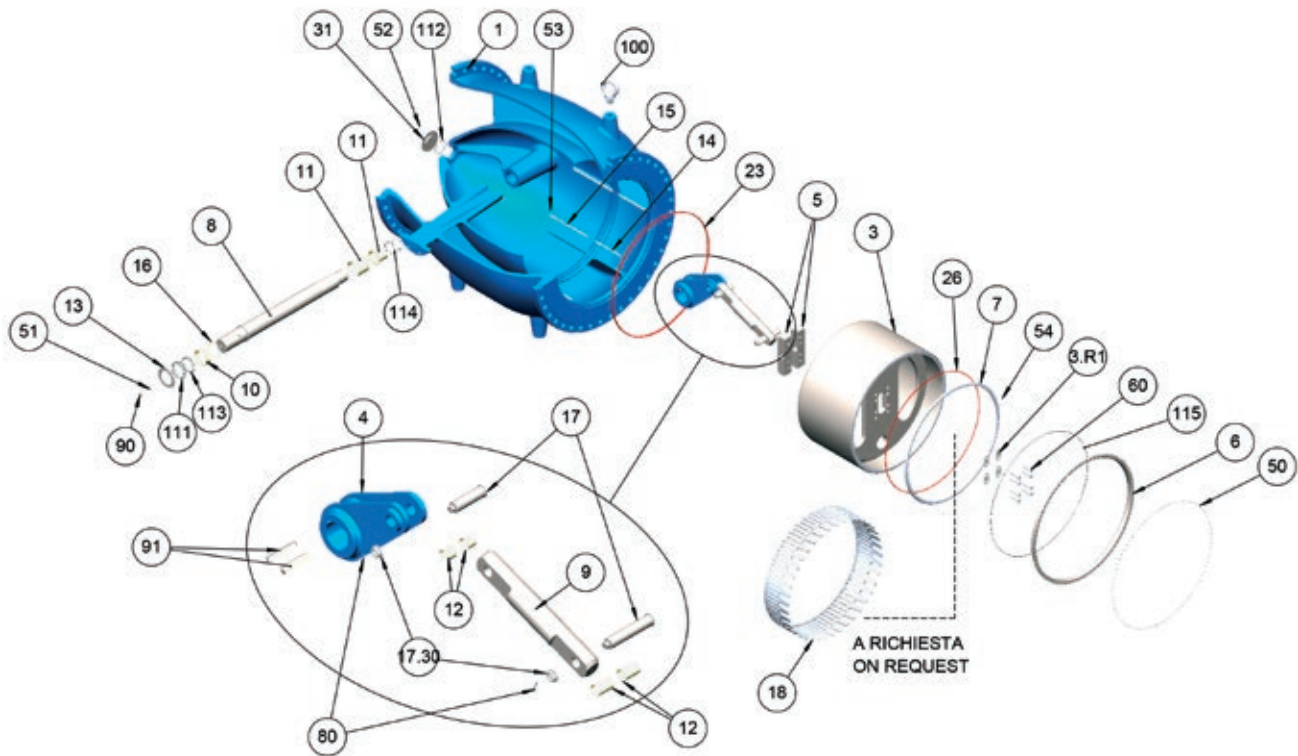

ITEM	COMPONENT	MATERIALS	NOTE
1	Body	EN-GJS 500-7 EN 1563 (GS500)	Epoxy coating 300 µm
3	Obturator (pipe, frontal ring and frontal plate)	1.4306 EN 10088-3 (AISI 304L)	
3.R1	Locking washer	1.4401 EN 10088-3 (AISI 316)	
4	Link	S275JR EN 1025-2 (Fe430B)	Epoxy coating 300 µm
5	Bracket-fork	1.4301 EN 10088-3 (AISI 304)	
6	Seating ring	1.4301 EN 10088-3 (AISI 304)	
8	Shaft	1.4028 EN 10088-3 QT850 (AISI 420 B)	
9	Connecting rod	1.4028 EN 10088-3 QT850 (AISI 420 B)	
10	Outer bearing	CC 333 G EN 1982 CuAl10Fe5Ni5-C	
11	Inner bearing	CC 333 G EN 1982 CuAl10Fe5Ni5-C	
12	Bearing	CC 333 G EN 1982 CuAl10Fe5Ni5-C	
13	Actuator coupling disk	1.4301 EN 10088-3 (AISI 304)	
14	Sliding blocks	CW 307 G M EN 12165 (Bronze)	
15	Sliding blocks	CW 307 G M EN 12165 (Bronze)	
16	Thrust bearing bushing	CC 333 G EN 1982 CuAl10Fe5Ni5-C (Bronze)	
17	Connecting rod	1.4028 EN 10088-3 QT850 (AISI 420 B)	
17.30	Connecting rod washer	1.4401 EN 10088-3 (AISI 316)	
18	Dissipating cylinder (on request)	1.4301 EN 10088-3 (AISI 304) / 1.4306 EN 10088-3 (AISI 304L)	
23	Lip seal	N-PU polyurethane elastomer	
26	Main seal	N-PU polyurethane elastomer	
31	Nose cone	1.4301 EN 10088-3 (AISI 304)	
50/51/52 53/54/60	Bolts	A2-70 EN ISO 3506-1	
80	Cotter pins	A2-70 EN ISO 3506-1	
90	Tongue	1.0511 EN 10083-2 +QT (C40B)	
91	Tongue (internal)	1.4028 EN 10088-3 QT850 (AISI 420 B)	
100	Eyebolt	Galvanized steel	
111-115	O-ring	EPDM rubber	

DIMENSIONS AND WEIGHTS

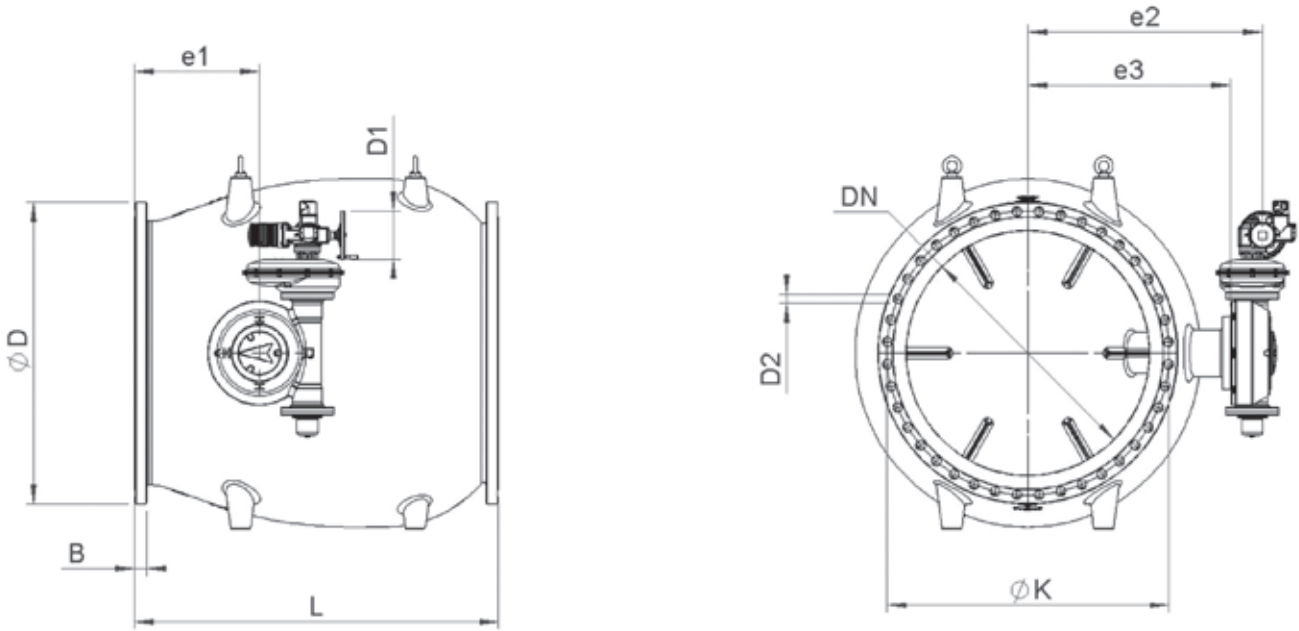

PN 10

DN	1600	1800
D [mm]	1915	2115
D1 [mm]	320	500
D2 [mm]	50	50
B ² [mm]	49	52
e1 [mm]	855	855
e2 [mm]	1610	1740
e3 [mm]	1365	1410
K [mm]	1820	2020
L [mm]	2300	2600
Holes [nr]	40	44
Weight ¹ [kg]	10480	13850

PN 16

DN	1600	1800
D [mm]	1930	2130
D1 [mm]	320	500
D2 [mm]	57	57
B ² [mm]	65	70
e1 [mm]	855	855
e2 [mm]	1610	1740
e3 [mm]	1365	1410
K [mm]	1820	2020
L [mm]	2300	2600
Holes [nr]	40	44
Weight ¹ [kg]	10500	14000

PN25

DN	1600	1800
D [mm]	1975	2195
D1 [mm]	320	500
D2 [mm]	62	70
B ² [mm]	81	88
e1 [mm]	855	855
e2 [mm]	1610	1740
e3 [mm]	1365	1410
K [mm]	1860	2070
L [mm]	2300	2600
Holes [nr]	40	44
Weight ¹ [kg]	11000	16000

1: gearbox included
 Inlet/outlet flange: Type B seal surface (raised face)

PRESSURE DROP

Pressure drop in plunger flow control valves can be evaluated using equation (1.a) or equation (1.b):

$$\Delta P = \xi \cdot V^2 / (2 g) \text{ [mhw]} \quad (1.a)$$

$$\Delta P = (Q / Kv)^2 \text{ [bar]} \quad (1.b)$$

Where:

- ΔP = pressure drop [unit: see formula above]
- ξ = pressure drop coefficient
- v = fluid speed referred to valve's DN [m/s]
- Kv = flow coefficient [m³/h]
- g = 9.81 [m/s²]
- Q = flow rate [m³/h]

The pressure drop coefficient ξ can be calculated using (2.a) and the flow coefficient Kv can be calculated using (2.a):

$$\xi = \xi^* \times \xi_{100} \quad (2.a)$$

$$Kv = Kv\% \times Kvs \quad (2.b)$$

Where:

- ξ_{100} is the pressure drop coefficient of the fully open valve. It is listed in Table_1 for standard valves (no dissipating cylinder). For valves equipped with dissipating cylinders, ξ_{100} is the distinctive value of the cylinder (e.g.: for a valve equipped with a K20 dissipating cylinder, it will be $\xi_{100} = 20$).
- ξ^* expresses the percentage change in the pressure drop as the degree of valve aperture varies ($\xi^* = \xi / \xi_{100}$). ξ^* is shown in Diagram_1.
- Kvs is the flow coefficient of the fully open valve and is listed in Table_1.
- $Kv\%$ expresses the percentage change of Kv as the degree of valve aperture varies. $Kv\% = Kv / Kvs$. $Kv\%$ is shown in Diagram_2.

PLUNGER FLOW CONTROL VALVES - HYDRAULIC SPECIFICATIONS																					
	F560				F500														F550		
DN	80	100	125	150	200	250	300	350	400	450	500	600	700	800	900	1000	1200	1400	1600	1800	
Kvs [m ³ /h]	145	203	310	430	678	1070	1550	2120	2785	3540	4395	6380	8750	11480	14580	18010	26020	35430	64100	81200	
ξ_{100}	3,1	3,8	4,0	4,3	5,5	5,4	5,3	5,2	5,2	5,1	5,1	5,0	4,9	4,9	4,8	4,8	4,8	4,8	2,5	2,5	

Table 1

DIAGRAM 1

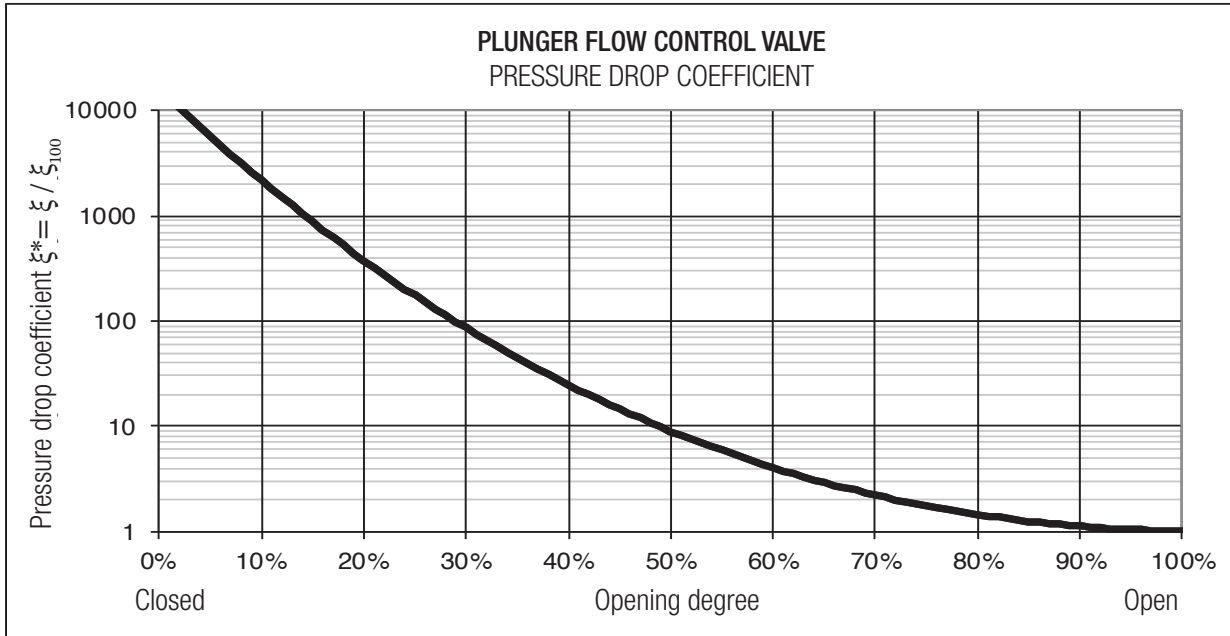
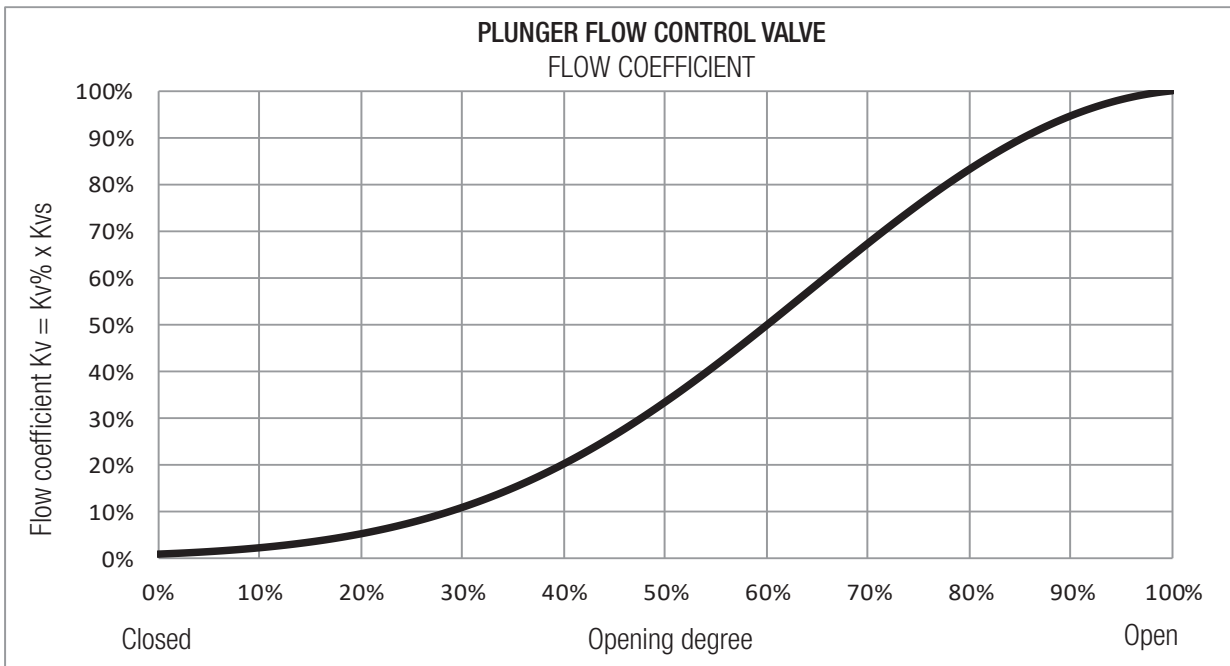

DIAGRAM 2



CAVITATION

Cavitation risk in plunger valves can be evaluated by using equation (3):

$$\sigma > \sigma_L \quad (3)$$

Where:

- Cavitation number $\sigma = P_{out} / (\Delta P + v^2/2g)$ (4)
- Cavitation limit σ_L is given in the diagram below
- ΔP = pressure drop [mhw]
- P_{out} = valve outlet pressure
- v = fluid velocity referred to valve's DN [m/s]
- g = 9.81 m/s²

The valve will not cavitate as long as $\sigma > \sigma_L$.

DIAGRAM 3

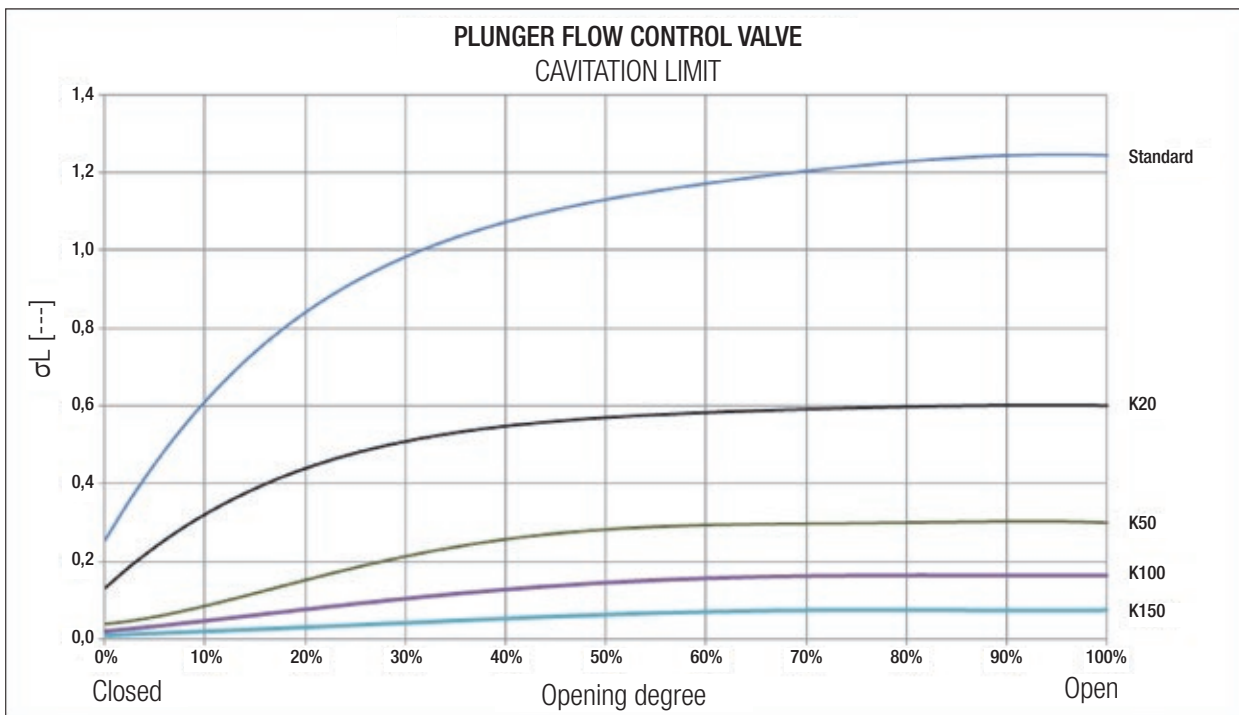

OPERATING DEVICES

PNEUMATIC ACTUATOR

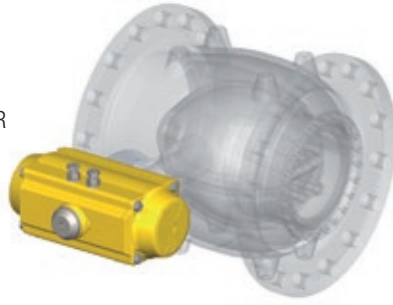

WORM GEARBOX AND HANDWHEEL

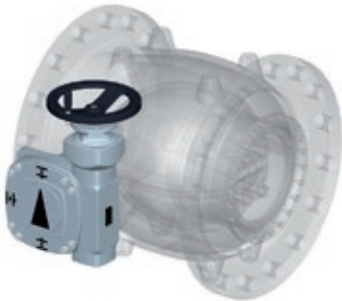

ELECTRIC ACTUATOR

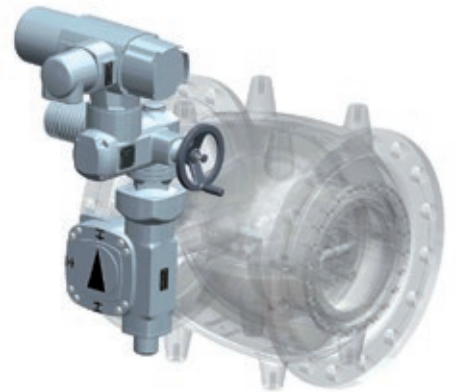

MAIN VALVE



DOUBLE-ACTING HYDRAULIC ACTUATOR

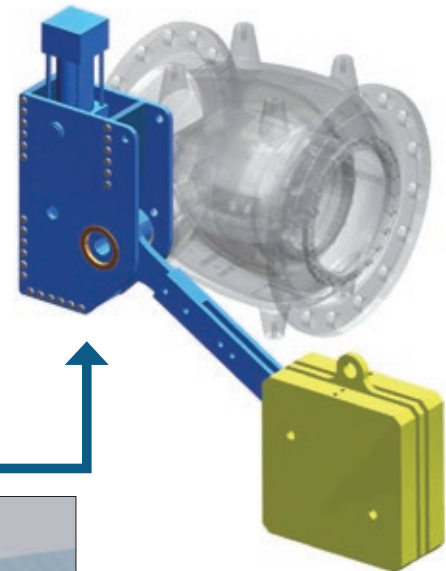

HYDRAULIC CYLINDER AND COUNTERWEIGHT

FLOAT ACTUATOR

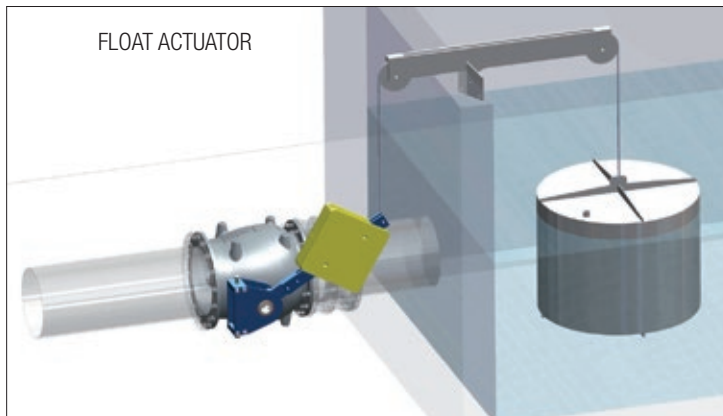

ACCESSORIES

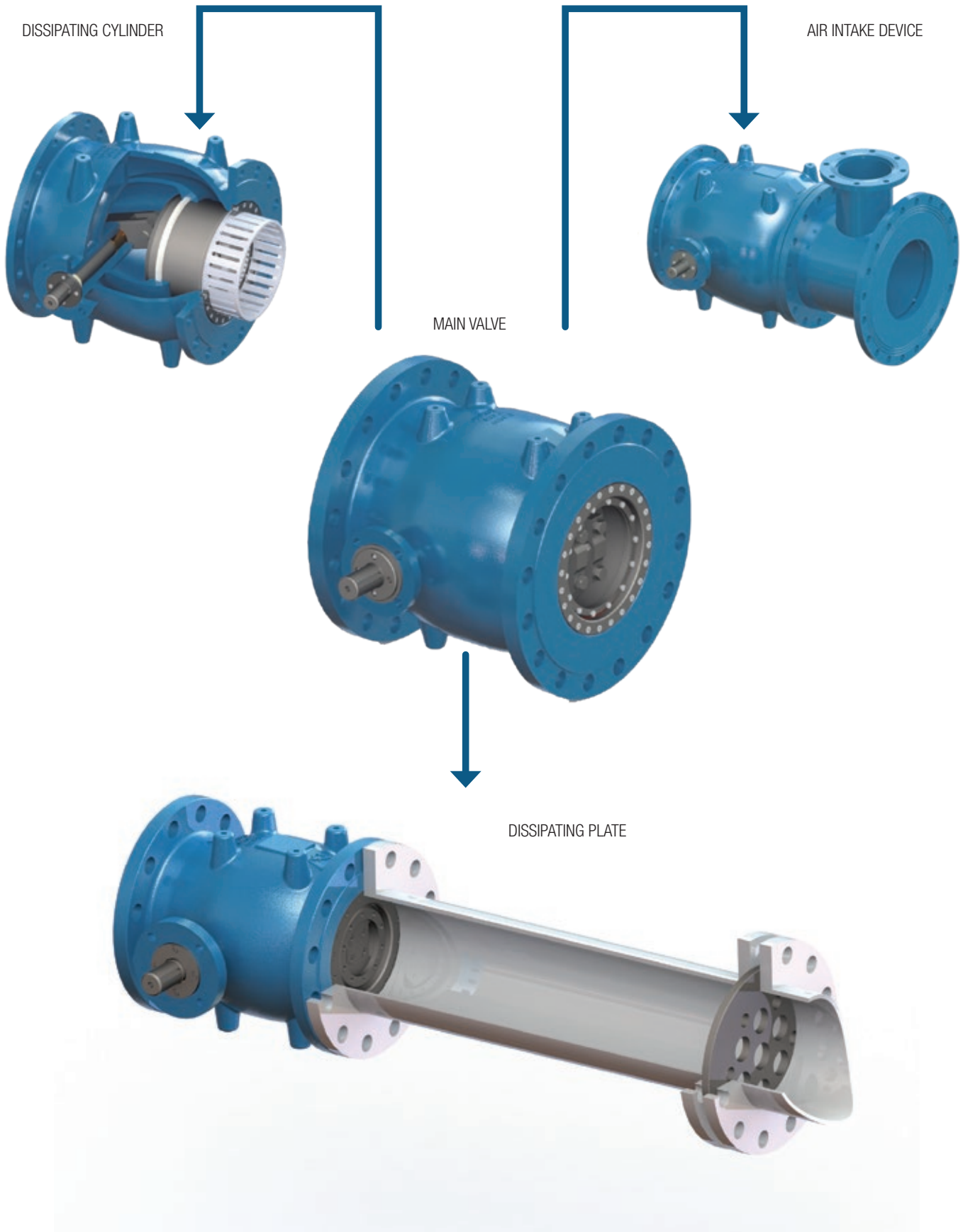

DISSIPATING CYLINDERS

The valve can be equipped with a stainless steel dissipating cylinder specially slotted to divide the outlet flow into radial fluid jets that collide at the valve centre axis. This device offers an energy dissipation curve adjusted to the real operating conditions of the valve and based on the plant's effective requirements. Standard slotted cylinders are available for progressively greater resistance to cavitation and increasing pressure drop. Special slotted cylinders can be fitted with the dimension, shape, and aperture calculated on the basis of the valve's effective operating conditions. For example, it is possible to limit headloss at higher valve apertures, and ensure high cavitation resistance at small apertures.

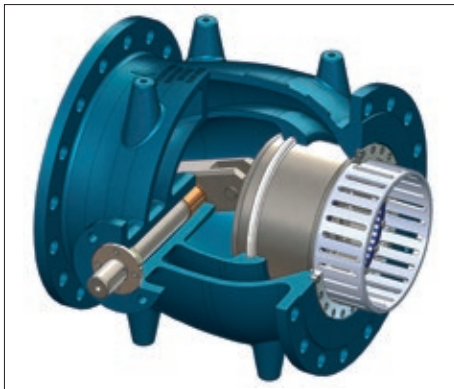

DIFFERENT TYPES OF DISSIPATING CYLINDERS



SPECIAL DISSIPATING CYLINDERS

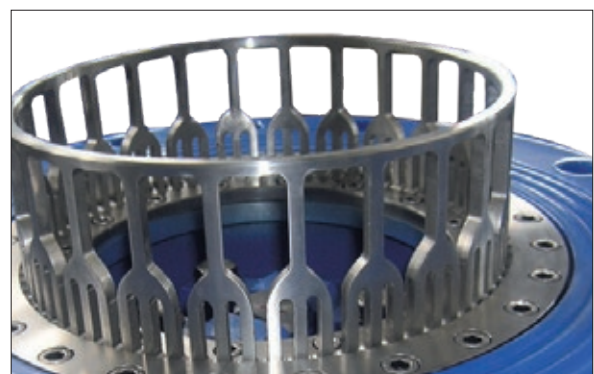

DISSIPATING PLATE

In the case of high hydraulic heads, when a dissipating cylinder is not enough to ensure adequate dissipation it should be combined with a perforated dissipating plate mounted downstream of the valve. A suitably designed plate will reduce the hydraulic head and support the dissipating action of the dissipating cylinder.

Depending on the number, size, and inclination of the holes, a dissipating plate provides different load dissipation values, improving the overall performance of the valve.

The recommended minimum pipe length upstream of a dissipating plate is $L_{PIPE} \geq 3 \times \text{Valve DN}$. The outside diameter of a dissipating plate is suitable for connection using a flange according to EN 1092-2. The recommended seal is flat type (on request, a dissipating plate can be made with O-ring seats).

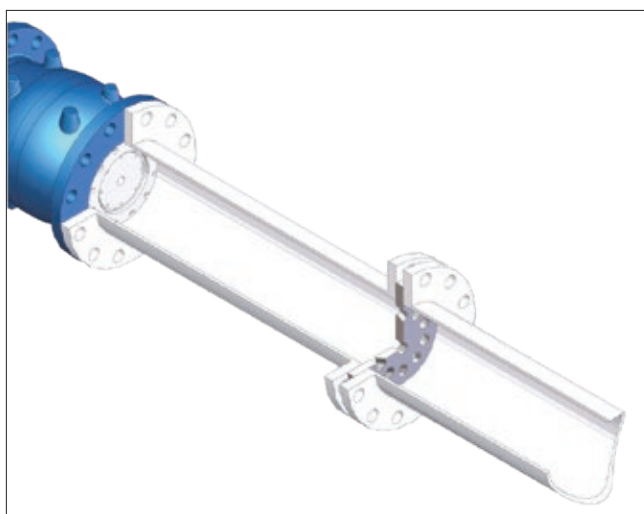
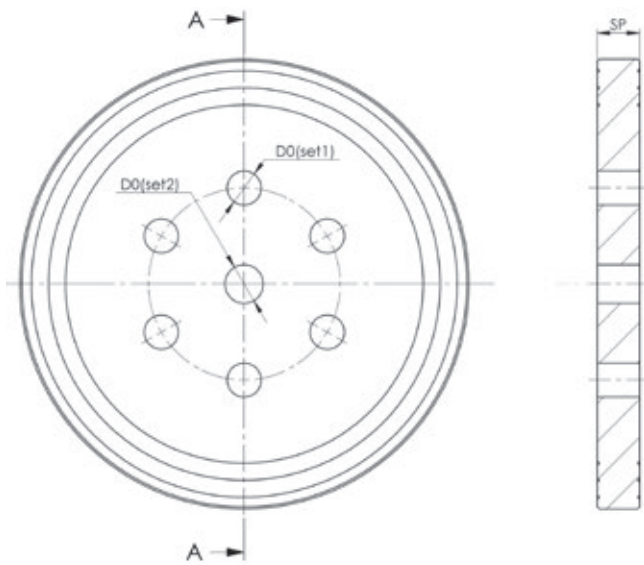

DISSIPATING PLATE DUCTED

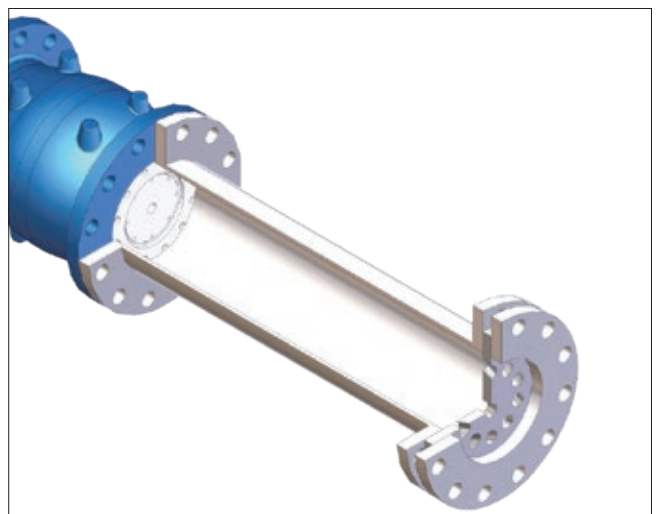

DISSIPATING PLATE - FREE DISCHARGE

AIR INTAKE DEVICE

Cavitation can occur due to depression in proximity to a flange or pipe downstream of a valve. This can be avoided by fitting the valve with an adequate air intake device to intake air and compensate the fluid depression, thus reducing the risk of cavitation, ensuring extended safe operation of the valve, and protecting the downstream section of the plant.

ATTENTION: The maximum working static pressure allowed for an air intake is 2 bar.

When an air intake is fitted, the Silencer AS accessory can be useful to limit noise emissions.

The Silencer AS is fitted directly onto the air intake:

- Low noise emission, Silences AS is able to reduce noise down up to 30 decibels;
- Easy to install;
- Cost saving, no need for piping to connect the air intake to the exterior.

We recommend providing the maneuver chamber with a ventilation opening to avoid occurrence of under pressure.

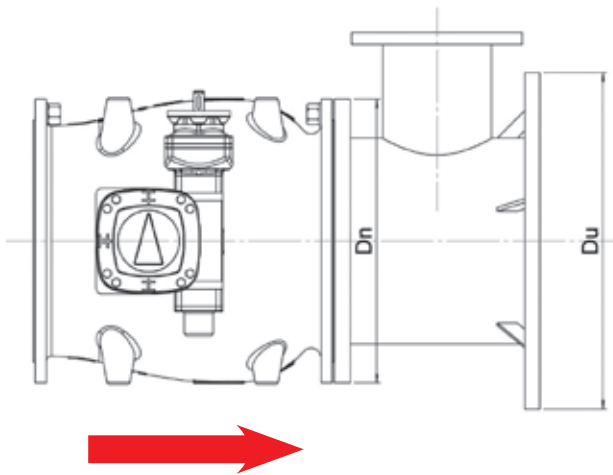

AIR INTAKE STANDARD DIMENSIONS					
DN valve	* = DOUBLE AIR INLET / ** = TO BE CONFIRMED				
[PN10/16]	Dn	Du	DN air inlet	Face to face	Weight [kg]
80	DN80	DN100	G 1" 1/4	180	10
100	DN100	DN125	DN50	250	16
125	DN125	DN150	DN50	250	26
150	DN150	DN200	DN65	280	30
200	DN200	DN250	DN80	340	45
250	DN250	DN300	DN100	350	60
300	DN300	DN400	DN125	360	95
350	DN350	DN450	DN150	420	130
400	DN400	DN500	DN200	460	185
450	DN450	DN600	DN200	550	215
500	DN500	DN600	DN200	600	255
600	DN600	DN700	DN250	680	340
700	DN700	DN800	DN300	850	420
800	DN800	DN900	DN300	865	530
900	DN900	DN1000	DN350	900	720
1000	DN1000	DN1200	DN400	1000	940
1200*	DN1200	DN1400	DN400	1200 (**)	1550
1400*	DN1400	DN1600	DN400	1400 (**)	1950
1600*	DN1600	DN1800	DN800	1470	3850

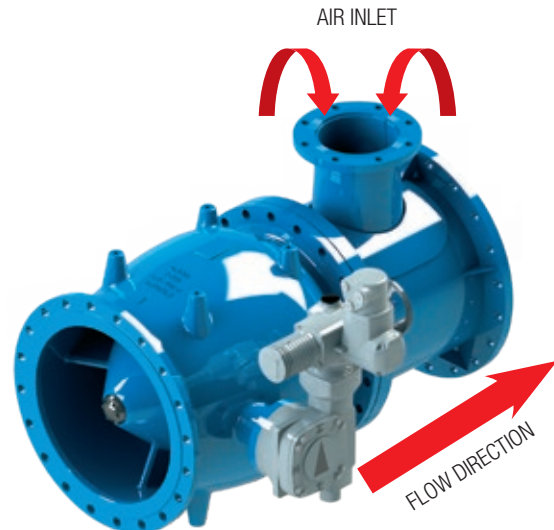

PLUNGER FLOW CONTROL VALVE WITH AIR INTAKE DEVICE AND SILENCER "AS"

F500RL • PLUNGER FLOW CONTROL VALVE WITH VULCANIZED HARD RUBBER LINING

Valves for saline media (seawater or well-desalination) or corrosive media have to resist chemical attack from chloride ions. Standard epoxy coated valve surfaces will be rapidly abraded due to the fluid aggressivity. The best possible solution to ensure extended valve life and safe operation of plants, is to entirely protect the internal valve surfaces with a hard rubber lining of 3 mm which ensures no metal parts come into contact with the aggressive fluids. The linings are applied by heating the elements to around 135°-145° C and vulcanizing rubber sheets onto the surfaces at a pressure of about 4.5 bar.

Other parts of the valve in contact with the fluids are made in duplex and AISI 316 stainless steel, offering high resistance to corrosion in the presence of ions dissolved in water.

Typical applications for these valves are: water treatment plants, desalination plants, mines, industrial water handling, mineral treatment plants.

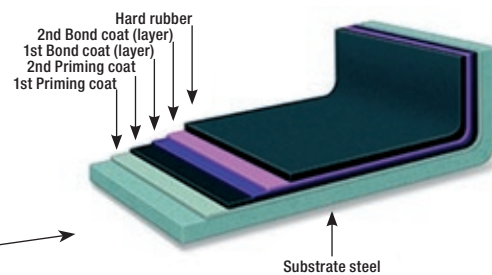
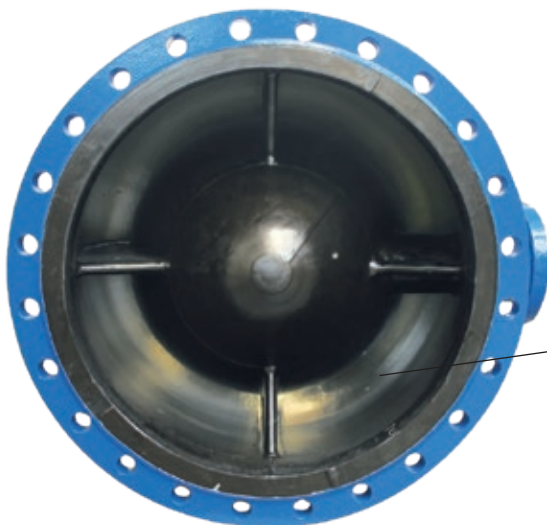

The valve body is internally covered with a rubber layer which provides additional protection to corrosion from brackish water and significantly increases the life of the valve.

F600 - F650 • PLUNGER FLOW CONTROL VALVE FABRICATED WELDED STEEL



In high pressure applications the valve body is made of fabricated welded steel P355N (DN500 and above forged steel), material with high mechanical strength and good weldability (PN100 - PN64 for big diameters)
Typical applications include: hydroelectric power plants with high hydraulic heads, snowmaking systems, testing systems, and systems subject to high pressure testing.



F600 PN100
HYDRAULIC TEST
(PRESSURE TEST = 150 BAR)



PLUNGER CHECK VALVE

Check valves are designed to perform a retaining function, typically downstream of pumping stations.

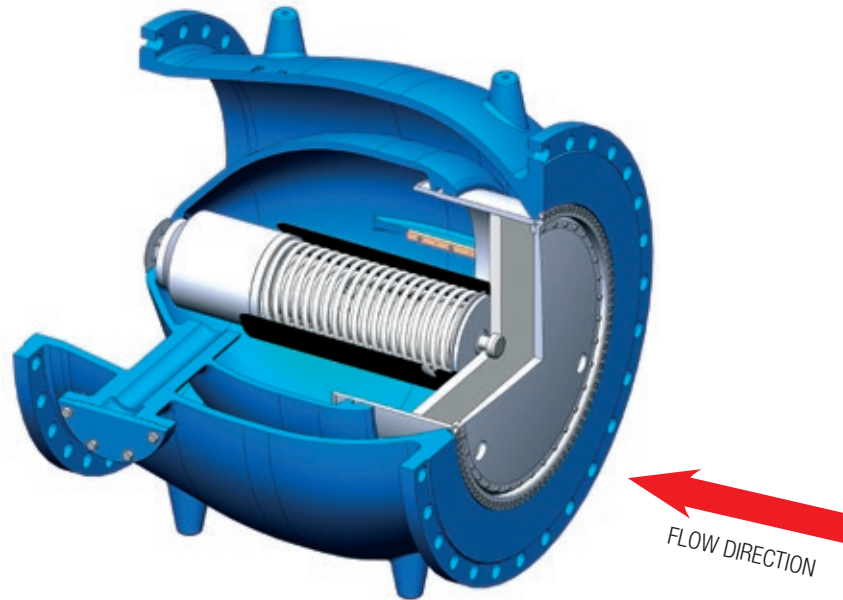

In the case of pump stoppage, a check valve provides rapid closure of the plunger by a spring system before the flow can reverse into the pump with a risk of damage. The seal is secured by the pressure generated in the inner barrel under backflow pressure, augmenting the action of the springs. The valve plunger is supported by four external self-lubricating guides, which guarantee a smooth sliding action. These features ensure the check valve high strength and reliability. Available two standard versions, to satisfy most customer needs:

TYPE “A” WITH OPERATING CIRCUIT



TYPE “B” WITHOUT OPERATING CIRCUIT



Other versions available on request.

MATERIALS AND COMPONENTS

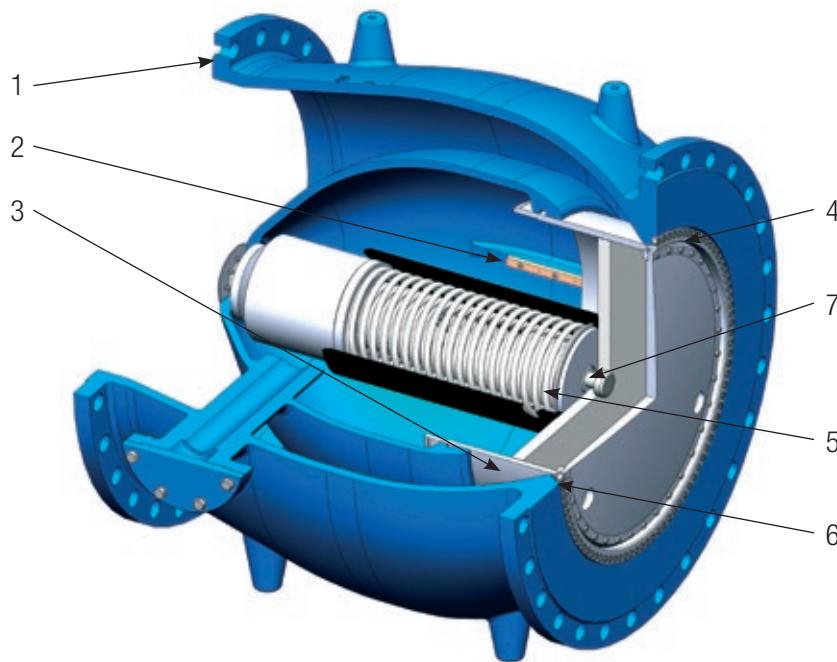

ITEM	COMPONENT	MATERIAL
1	Body	Ductile iron
2	Guides	Marine bronze
3	Plunger (shutter)	Stainless steel (AISI 304)
4	Seating ring	Stainless steel (AISI 304)
5	Springs	Stainless steel for springs
6	Main seal	N-PU polyurethane elastomer
7	Spring guide components	Stainless steel (AISI 304)
	Main components of the pilot circuit (when present - optional)	Stainless steel (AISI 304)

VALVE RANGE*				
PN	10/16	25	40	64
DN	80 - 1000	80 - 600	80 - 500	80 - 150

* For the overall dimensions of check valves, refer to those of the plunger valves previously mentioned.

MAIN APPLICATIONS

FLOW AND PRESSURE CONTROL

The most frequently used valves for pressure reduction or flow control are diaphragm valves, but these have limitations as regards hydraulic behaviour and size. Plunger valves are also perfectly suited for precise and reliable control of pressure and flow, and they have the advantage of nominal diameters ranging from DN 80 to DN 1800. Unlike diaphragm valves (only operated hydraulically), plunger valves require an external actuator, which can be operated manually, electrically, pneumatically, hydraulically, by float devices, or by gravity (cylinder with counterweight). Pressure or flow can be controlled using external actuators to reduce or increase the inner cross-section of the valve, commanded by an external unit (PLC) connected to pressure gauges (fitted upstream and downstream of the plunger valve) or a flow meter (mounted upstream of the plunger valve).

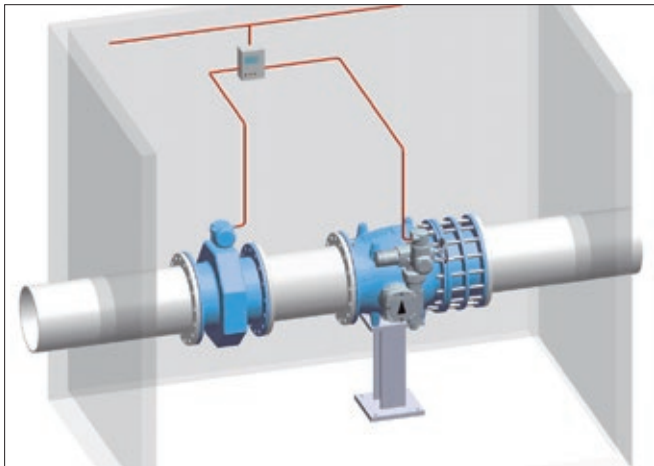

FLOW CONTROL CONFIGURATION

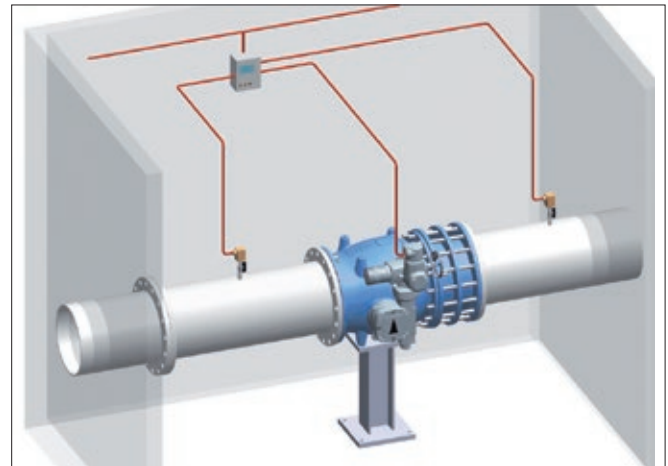

PRESSURE CONTROL CONFIGURATION

LEVEL CONTROL

Plunger valves can control reservoir filling to maintain a constant water level regardless water demand.

It is important to carefully select the valve diameter according to the system's hydraulic parameters: if the valve is oversized, there could be fluctuations in tank level or the time needed to reach the desired level may be too long.

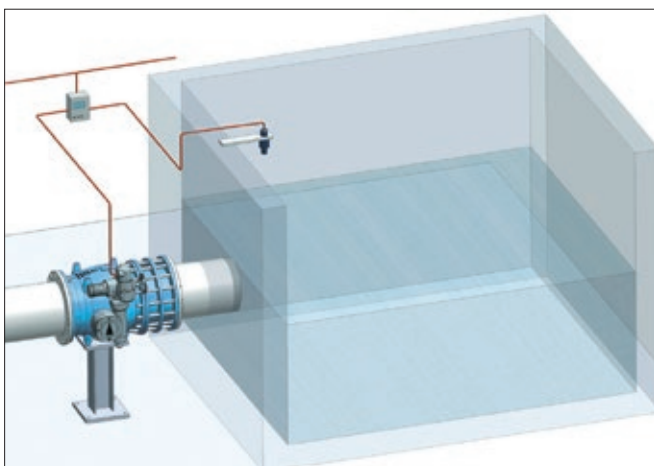

WITH ELECTRIC TYPE ACTUATOR AND LEVEL SENSOR

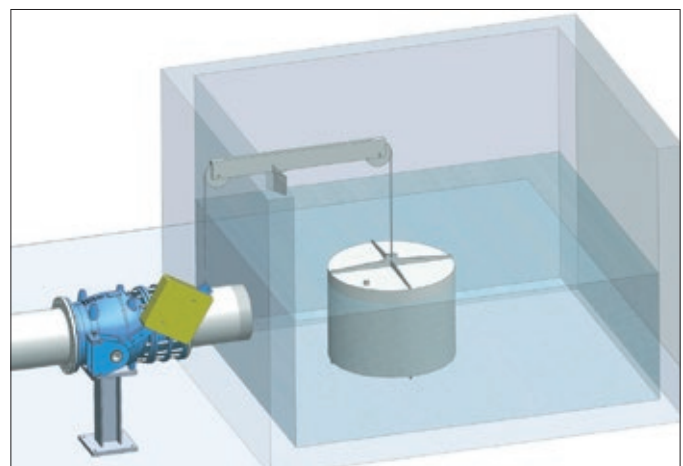

WITH COUNTERWEIGHT SYSTEM AND FLOAT

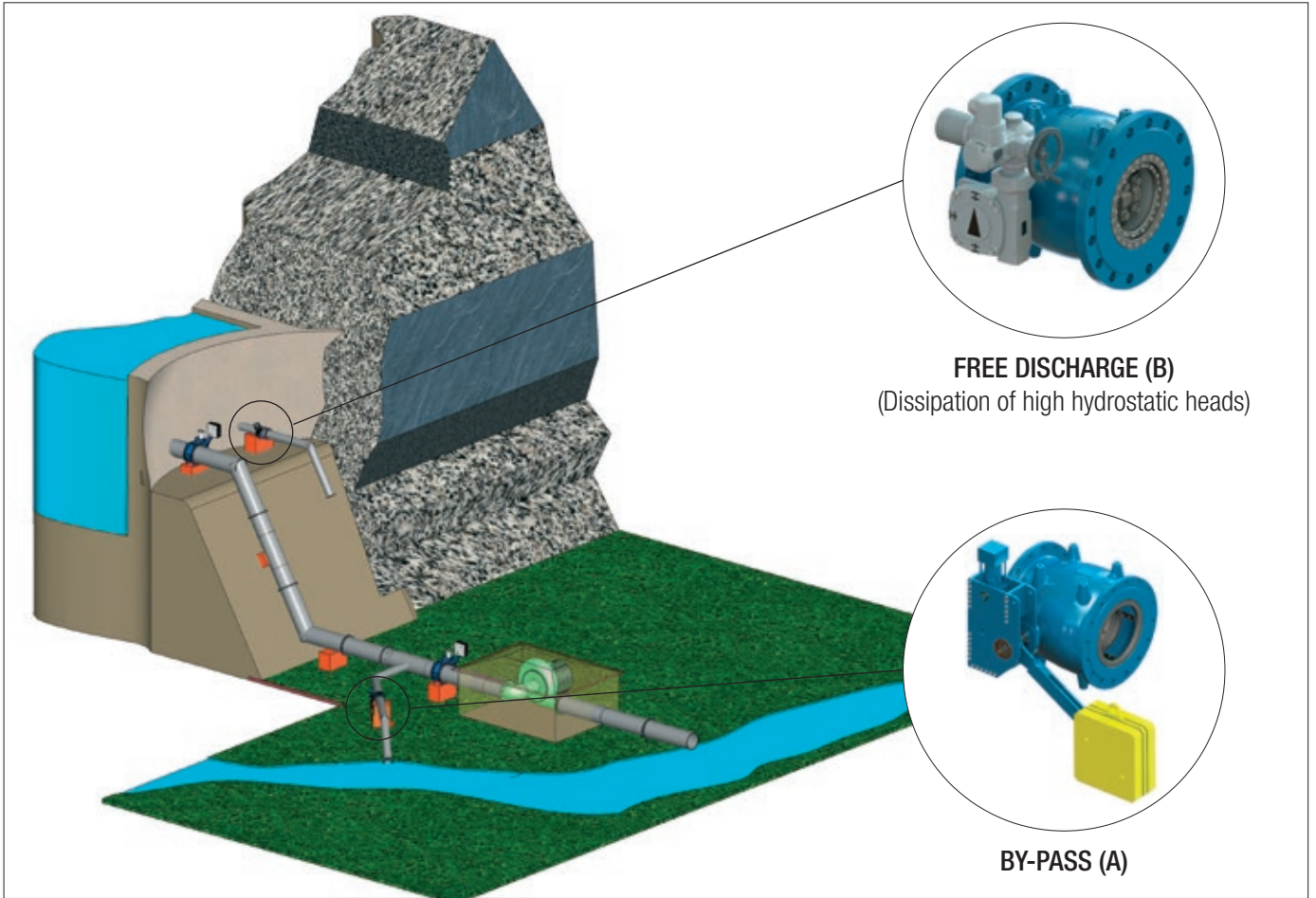

A • BY-PASS VALVE

A plunger valve can be used as a:

- By-pass valve for hydroelectric installations for the protection of the turbine-generator or when servicing the turbine;
- By-pass valve for filling large pipelines.

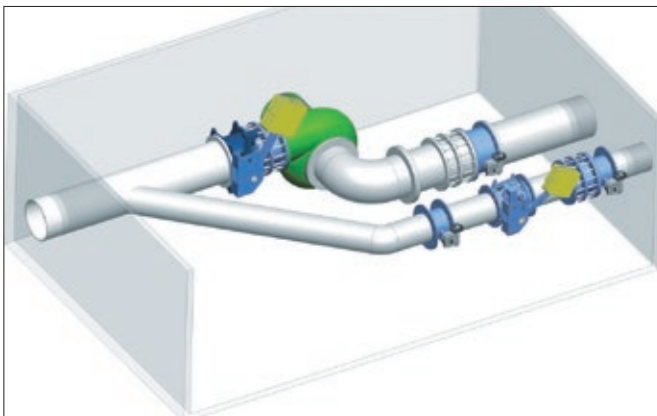

BY-PASS FOR TURBINE-GENERATOR

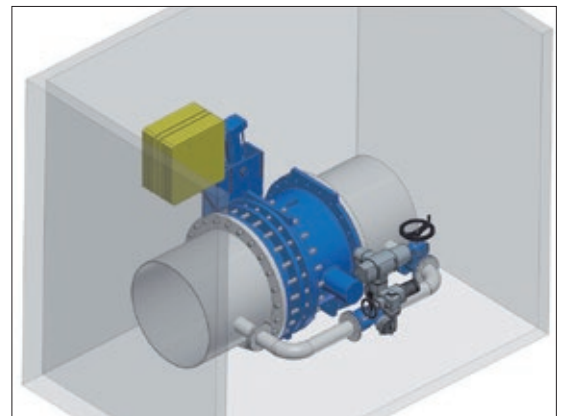

BY-PASS FOR FILLING LARGE PIPELINES

B • DISSIPATION OF HIGH HYDROSTATIC HEADS

Plunger valves are used for free discharge outlets. A typical example is a dam base discharge valve.

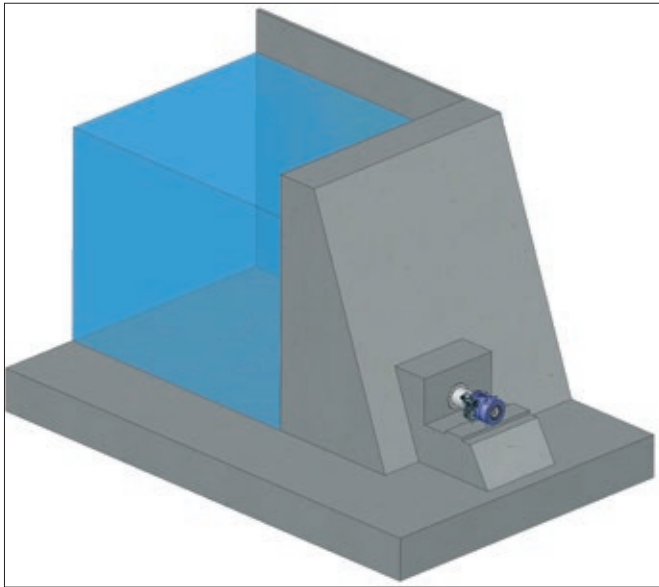

AIR APPLICATIONS

Plunger valves can be used to regulate the rate of air flow into water treatment plants.



Fig.1, 2 - Plunger valve for regulating air flow into a nitrification tank: the valve is equipped with an electrical actuator.

MAIN FEATURES

- Precise adjustment to regulate the rate of air flow based on the tank's dissolved oxygen concentration parameters.
- Optimized blower operation with resulting overall energy savings for the plant.

TECHNICAL SPECIFICATIONS

Valve pressure drop:	up to 1 bar
Operating temperature:	+0°C to 90°C / (+0°C to 110°C on request)
Typical applications:	In water treatment plants, downstream of blowers for the input of air into tanks (nitrification, preliminary treatments, etc.).

Valves can be used with various gasses including: air, nitrogen, carbon dioxide. NOT for flammable, corrosive or hazardous gasses. In air applications, the use of a slotted cylinder permits optimization of valve performance, modifying the adjustment curve on the basis of effective requirements. This makes it possible to adjust the shutter travel on the basis of flow variation. Slotted cylinders are available for progressively greater pressure drop.

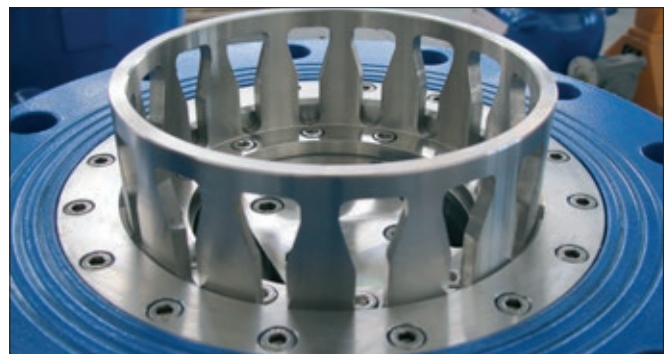
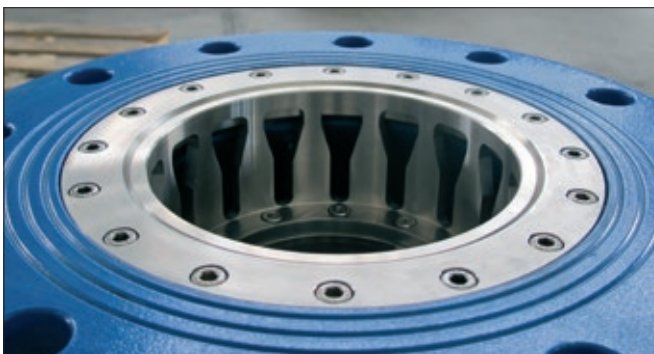

PLUNGER VALVE FOR AIR WITH SLOTTED CYLINDER