



PN10 - ART. D158 M

PN16 - ART. D159 M

**VALVOLA A FARFALLA U-SECTION [DN700 - DN1200] FLANGIATA PN10-PN16
PRESSIONE DI ESERCIZIO 10 BAR**

**U-SECTION BUTTERFLY VALVE PS10 [DN700 - DN1200] FLANGED PN10-PN16
WORKING PRESSURE 10 BAR**



APPLICAZIONE:

Fornitura, raccolta, distribuzione di acqua, reti per la raccolta e deflusso acque di scarico.

APPLICATION:

Water supply and distribution, waste water treatment.

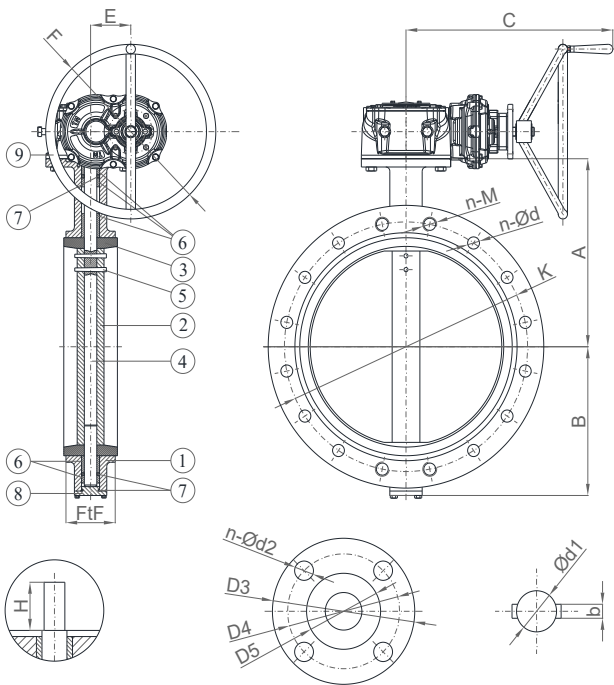

DN700-1200

Riduttore di sforzo predisposto per attuatore multi-giro con flangia ISO.	Gearbox input shaft with ISO top flange for multi-turn actuator coupling.
DN700 - DN1000	DN1200
F10	F14

RIVESTIMENTO - COATING	
Esterno con polvere epossidica di colore blu RAL 5015 e spessore 250µm.	
External FBE coating process with epoxy resin powder of blue colour RAL 5015 and thickness of 250µm.	

CARATTERISTICHE PRINCIPALI - MAIN FEATURES	
NORMA PROGETTO:	EN 593, EN 1074-1 ed EN 1074-2
SCARTAMENTO:	EN 558 Serie 20
FLANGE:	EN 1092-2 PN10 o PN16
COLLAUDI:	EN 12266-1
FLANGIA SUPERIORE:	ISO 5211
TEMPERATURA ESERCIZIO:	EPDM ≤ +90°C NBR ≤ +70°C
PRESSIONE DI ESERCIZIO:	PS 10 bar
DESIGN STANDARD:	EN 593, EN 1074-1 ed EN 1074-2
FACE TO FACE:	EN 558 Serie 20
FLANGES:	EN 1092-2 PN10 or PN16
TESTS:	EN 12266-1
TOP FLANGE:	ISO 5211
WORKING TEMPERATURE:	EPDM ≤ +90°C NBR ≤ +70°C
WORKING PRESSURE:	PS 10 bar

	COMPONENTI PARTS	MATERIALI MATERIALS
1	CORPO BODY	EN-GJS 400-15 EN-GJS 400-15
2	DISCO DISC	INOX AISI 304 SS AISI 304
3	TENUTA SEAT	EPDM (a richiesta NBR) EPDM (NBR on request)
4	ALBERO STEM	ACC. INOX AISI 420 (EN 1.4021) SS AISI 420 (EN 1.4021)
6	BOCCOLA BUSHING	FIBRA DI VETRO + PTFE FIBERGLASS + PTFE
7	O-RING O-RING	EPDM EPDM
8	COPERCHIO COVER	EN-GJS 400-15 EN-GJS 400-15
9	RIDUTTORE GEAR BOX	EN-GJS 400-15 EN-GJS 400-15

DN	K		n-Ød		n-M		D3	D4	D5	n-Ød2	Ød1	b	H	A	B	C	E	F	FtF	W (kg)
	PN10	PN16	PN10	PN16	PN10	PN16														
700	840	840	20-31	20-37	4-M27	4-M33	300	254	200	8-18	60	18	100	624	520	500	119	400	165	237
750	900	900	20-34	20-37	4-M30	4-M33	300	254	200	8-18	60	18	110	660	545	550	112	400	165	370
800	950	950	20-34	20-41	4-M30	4-M36	300	254	200	8-18	60	18	110	672	591	550	112	400	190	410
900	1050	1050	24-34	24-41	4-M30	4-M36	300	254	200	8-18	72	20	118	720	656	583	112	400	203	547
1000	1160	1170	24-37	24-44	4-M33	4-M39	350	298	230	8-22	80	22	142	800	721	583	112	400	216	887
1200	1380	1390	28-41	28-50	4-M36	4-M45	350	298	230	8-22	105	28	154	941	844	583	112	400	276	1351