

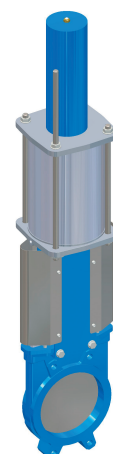

PN 10 - ART. A013/Z-SE NC



VALVOLA A GHIGLIOTTINA MONODIREZIONALE MONOBLOCCO CON ATTUATORE PNEUMATICO A SINGOLO EFFETTO NC
MONOBLOCK NC SINGLE ACTING PNEUMATIC CYLINDER UNIDIRECTIONAL KNIFE GATE VALVE

APPLICAZIONE:

Fornitura e distribuzione acqua, trattamento acque reflue e sistemi fognari, settori industriali.

APPLICATION:

Water supply and distribution, waste water treatment and sewerage.

CARATTERISTICHE PRINCIPALI - MAIN FEATURES

<p>FLANGE: COLLAUDI: TEMPERATURA ESERCIZIO: MAX PRESSIONE AMMISSIBILE DI ESERCIZIO(PS):</p>	<p>Foratura secondo EN 1092-2 PN10 EN 12266-1 in accordo alla PS della valvola Max. ≤ +90°C 3bar</p>	<p>FLANGES: TESTS: WORKING TEMPERATURE: MAX ALLOWABLE WORKING PRESSURE (PS):</p>	<p>Drilled according to EN 1092-2 PN10 EN 12266-1 according to the valve PS Max. ≤ +90°C 3bar</p>
--	---	---	--

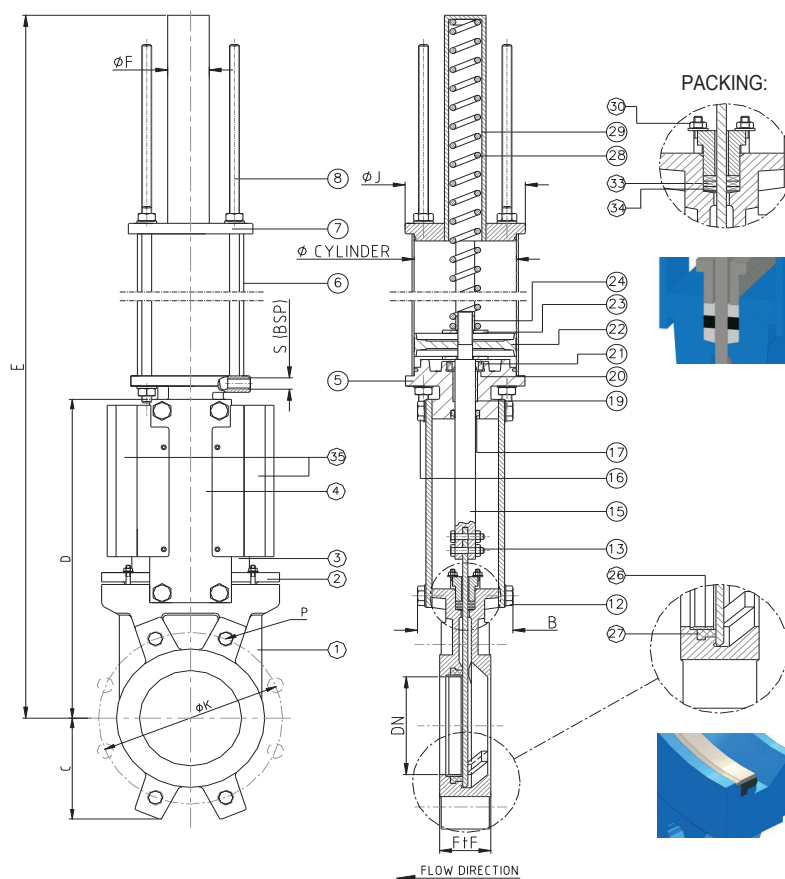

DN	K	n-M	FIF	B	C	D	E	Ø F	Ø CYLINDER	Ø J	S (B.S.P)	W (kg)
50	125	4-M16	40	90	65	240	720	89	125	147	1/4"	19
65	145	4-M16	40	90	68	270	766	89	125	147	1/4"	22
80	160	8-M16	50	90	90	295	810	89	125	147	1/4"	23
100	180	8-M16	50	90	105	335	875	89	125	147	1/4"	24
125	210	8-M16	50	100	120	370	975	89	160	182	1/4"	35
150	240	8-M20	60	100	135	418	1066	89	160	182	1/4"	36
200	295	8-M20	60	120	170	522	1380	114	200	225	1/4"	66
250	350	12-M20	70	120	205	625	1792	114	250	279	3/8"	130
300	400	12-M20	70	120	240	725	1932	114	250	279	3/8"	143



PN 10 - ART. A013/Z-SE NC

	COMPONENTI - PARTS	MATERIALI - MATERIALS
1	CORPO BODY	EN-GJL 250 EN-GJL 250
2	PREMISTOPPA PACKING GLAND	ALLUMINIO ALUMINUM
3	PARATIA KNIFE	ACCIAIO INOX AISI 304L AISI 304L STAINLESS STEEL
4	SUPPORTO SUPPORT	ACCIAIO STEEL
5	TESTATA INFERIORE LOWER CUP	ALLUMINIO ALUMINUM
6	CILINDRO PNEUMATIC TUBE	ALLUMINIO ALUMINUM
7	TESTATA SUPERIORE UPPER CUP	ALLUMINIO ALUMINUM
8	TIRANTI E BULLONERIA TIE RODS & BOLTS	ACCIAIO ZINCATO GALVANIZED STEEL
12 - 13 16	BULLONI BOLTS	ACCIAIO INOX A2-70 A2-70 STAINLESS STEEL
15	ASSE STEM	ACCIAIO INOX AISI 303 AISI 303 STAINLESS STEEL
17	RASCHIATORE SCRAPER	GOMMA NBR NBR RUBBER
19	BOCCOLA BUSH	BRONZO BRONZE
20	GUARNIZIONE GASKET	GOMMA NBR NBR RUBBER
21	PREMIGUARNIZIONE SEALING GLAND	ACCIAIO INOX AISI 316 AISI 316 STAINLESS STEEL
22	PISTONE PISTON	GOMMA NBR NBR RUBBER
23 - 24	DADO E RONDELLA NUT AND WASHER	ACCIAIO INOX A2-70 A2-70 STAINLESS STEEL
26	ANELLO DI TENUTA SEAT RING	ACCIAIO INOX AISI 316L AISI 316L STAINLESS STEEL
27	GUARNIZIONE GASKET	GOMMA EPDM EPDM RUBBER
28	MOLLA SPRING	ACCIAIO PER MOLLE SPRING STEEL
29	TUBO PROTETTORE MOLLA SPRING PIPE	ACCIAIO STEEL
30	BULLONI BOLTS	ACCIAIO INOX A2-70 A2-70 STAINLESS STEEL
33	O-RING BADERNA PACKING O-RING	EPDM EPDM
34	BADERNA PACKING	CORDA TEFLONATA SYNTETIC FIBERS + PTFE
35	PROTEZIONI PROTECTIONS	ACCIAIO INOX AISI 304 AISI 304 STAINLESS STEEL

RIVESTIMENTO - COATING

Esterno/interno con polvere epossidica di colore blu RAL 5015 e spessore 80µm.

External/internal epoxy resin powder of blue colour RAL 5015 and thickness of 80µm.