



FILTRO A "Y" PN16

"Y" TYPE STRAINER PN16

APPLICAZIONE:

Acqua e altri liquidi non pericolosi per sistemi industriali (compatibili con i materiali della valvola).

APPLICATION:

Water and other non-hazardous liquids for industrial systems (compatible with valve materials).

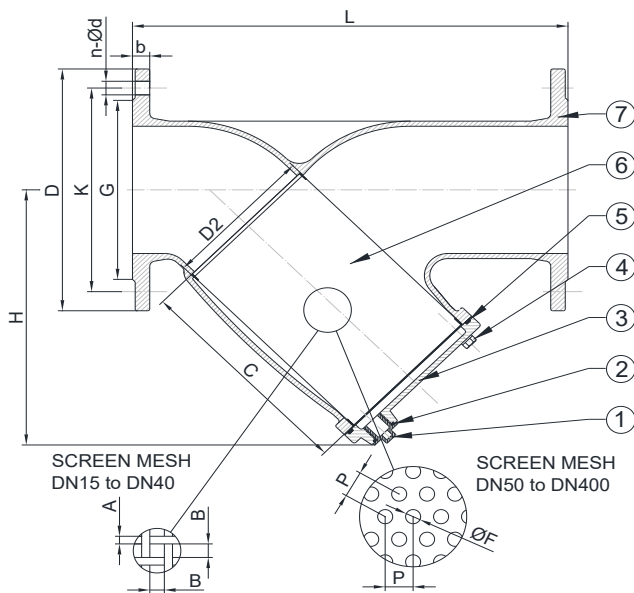

CARATTERISTICHE PRINCIPALI - MAIN FEATURES

SCARTAMENTO:	EN 558 Serie 1
FLANGE:	EN 1092-2
COLLAUDI:	EN 12266-1
TEMPERATURA ESERCIZIO:	Max. +100°C
FACE TO FACE:	EN 558 Serie 1
FLANGES:	EN 1092-2
TESTS:	EN 12266-1
WORKING TEMPERATURE:	Max. +100°C

	COMPONENTI - PARTS	MATERIALI - MATERIALS
1	TAPPO DRENAGGIO DRAIN PLUG	ACCIAIO INOX A2-70 A2-70 STAINLESS STEEL
2	O-RING O-RING	SILICONE SILICON RUBBER
3	COPERCHIO COVER	GHISA SFEROIDALE EN-GJS 500-7 DUCTILE IRON EN-GJS 500-7
4	VITERIA FASTENERS	ACCIAIO INOX A2-70 A2-70 STAINLESS STEEL
5	GUARNIZIONE GASKET	SILICONE SILICON RUBBER
6	FILTRO SCREEN	ACC.INOX AISI 304 (EN 1.4301) SS AISI 304 (EN 1.4301)
7	CORPO BODY	GHISA SFEROIDALE EN-GJS 500-7 DUCTILE IRON EN-GJS 500-7

RIVESTIMENTO - COATING

Colore blu RAL 5000.
Blue colour RAL 5000.

DN	15	20	25	32	40	50	65	80	100	125	150	200	250	300	350	400
L	130	150	160	180	200	230	290	310	350	400	480	600	730	850	980	1100
H	78.5	84.5	87.5	105	108	135	160	184	211	262	301	370	486	582	650	714
D	95	105	115	140	150	165	185	200	220	250	285	340	405	460	520	580
K	65	75	85	100	110	125	145	160	180	210	240	295	355	410	470	525
G	46	56	65	76	84	99	118	132	156	184	211	266	319	370	429	480
b	14	16	16	18	19	19	19	19	19	19	19	20	22	24,5	26,5	28
n-ød	4-14	4-14	4-14	4-19	4-19	4-19	4-19	8-19	8-19	8-19	8-23	12-23	12-28	12-28	16-28	16-31
A	Ø0.4	Ø0.4	Ø0.4	Ø0.4	Ø0.4	-	-	-	-	-	-	-	-	-	-	-
B	0.83	0.83	0.83	0.83	0.83	-	-	-	-	-	-	-	-	-	-	-
ØF	-	-	-	-	-	2.0	2.0	2.0	2.0	2.0	3.0	3.0	3.0	3.0	3.0	3.0
P	-	-	-	-	-	4	4	4	4	4	5	5	5	5	5	5
BSP	NA	NA	1/2"	1/2"	1/2"	1/2"	1/2"	1/2"	3/4"	3/4"	3/4"	3/4"	3/4"	3/4"	1"	1"
C	59	65	68	89	89	118	147	160	184	241	253	282	429	505	549	595
D2	22	27	32	39	47	55	77	87	109	139	169	209	268	318	368	418
W (kg)	2.2	2.5	4.0	4.5	6.0	7.6	10.6	12.0	16.0	25.5	33.0	60.5	93.0	135	213	260