

Digital electropneumatic positioner



Type 8791 BASIC can be combined with...



Yoke type actuators



Rack/pinion actuators

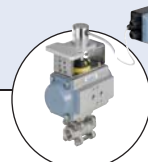

Rack/pinion actuators with remote positioner



Process control valve with remote positioner



Hygienic process control valve with remote positioner

- Compact and robust design
- Easy to start using tune function
- Dynamic positioning system with no air consumption in controlled state
- AS-Interface Fieldbus (optional)
- Mounting acc. to IEC 534-6 / VDI VDE 3845 or Remote

The robust and compact positioner is designed to a standardisation acc. to IEC 534-6 or VDI/VDE 3845 for assembly with linear and rotary actuators. In addition, the remote version with the displacement position sensor can be combined with Bürkert process control valves

The setpoint setting for the electro-pneumatic digital Positioner SideControl BASIC occurs using a standard signal 4...20mA or with AS-Interface as an option. In addition there is a binary input and an optional analogue feedback available.

The valve opening is signalled by a mechanical indicator element and the device status is shown on three coloured LEDs. All the operational elements are found in the housing.

The start-up happens automatically, and directly at the device the following functions by a DIP switches are activated:

- Close tight function
- Inversion of the operating direction of the setpoint signal
- Characteristic curves selection
- Switching - manual and automatic operation

Additional possibilities on configuration and parameter setting, for example, linearisation of the operation characteristics by using communications software which allows customised programming

The pilot valve system can be used equally for single and double-acting drives. It is characterised by a defined safety feature in case of failure of the electrical or pneumatic power supply and possesses an enormous air capacity range with pressure supply up to 7 bar.

Technical data	
Material	
Body	Aluminium plastic-coated
Seal	EPDM, NBR, FKM
Operating voltages	24 V DC +/- 10%
Residual ripple	max. 10%
Setpoint setting	4-20mA (0-20mA adjustable using configurations software)
Input resistance	0/4 to 20 mA: 180 Ω
Analogue feedback	(0-20mA adjustable using configurations software) (max. Burden 560Ω)
Binary input	0-5 V = log "0", 10-30 V = log "1"
Control medium	Neutral gases, air DIN ISO 8573-1
Dust concentration	Class 5 (<40µm particle size)
Particle density	Class 5 (<10mg/m ³)
Pressure condensation point	Class 3 (<-20°C)
Oil concentration	Class 5 (<25mg/m ³)
Ambient temperature	0 to +60°C
Pilot air ports	Threaded ports G 1/4
Supply pressure	1.4 bis 7 bar ^{1) 2)}
air supply filter	Exchangeable (mesh aperture~0.1mm)
Actuator system	
Air capacity	Single and double-acting up to 150 l _N /min. 50 l _N /min (with 1.4 bar ²⁾) for aeration and ventilation 150 l _N /min (with 6 bar ²⁾) for aeration and ventilation (Q _{Nn} = 100 l _N /min (acc. to the definition with decrease in pressure from 7 to bar absolute)
Position detection module	Potentiometer max. angle 180°
Stroke range valve spindle	Min. 30° on the rotary shaft, depending on lever
Installation	As required, display above or sideways
Type of protection	IP65 and IP67 acc. to EN 60529 (NEMA4x in preparation)
Power consumption	< 3.5 W

¹⁾ The supply pressure has to be 0.5-1 bar above the minimum required pilot pressure for the valve actuator

²⁾ Pressure values [bar]: Overpressure with respect to atmospheric pressure

continued on next page

Technical data, continued

Technical data	
Electrical connection	M12, 8-pin
Multipole connection	2xM20x1.5 (cable Ø 10mm) on screw terminals (0.14-1.5 mm ²)
Cable gland	1xM12x1.5 (cable Ø 3 to 6.5 mm)
Remote Version	
Protection class	3 acc. to VDE 0580
Type of ignition protection	II 3 G nA IIC T4 II 3 D tD A22 T135° C
Conformity	EMC directive 2004/108/EC
CSA approval information	
Product category code	Class 3221 82-VALVES - Actuators - Certified to US standards Class 3221 02-VALVES - Actuators
Considered standards	CAN/CSA-C22 2 No. 139 UL 429
CSA trademark	

Technical data - AS-interface (Option)	
Profile	S-7.3.4 Output: 16 Bit Set point/Certificate No. 87301 acc. to Version 3.0 S-7.A.5 Output: 16 Bit set point; Input: 16 Bit feedback/certificate No. 95401 acc. to Version 3.0
Programmed data	see instruction manual
Operating voltage over Bus connection	29,5 to 31,6 VDC acc. to Specification
Max. current consumption	150 mA
Electrical connection	M12x1,4-pin stainless steel connection assembled with 80cm cable and flat cable clamp

Technical data - Linear Remote Position Sensor (ELEMENT, CLASSIC)	
Electrical connection	1xM16x1.5 (cable Ø 5-10 mm) on terminal screws (0.14-1.5 mm ²)
Cable gland	
Connection cable length	10 m
Operating voltage	24V DC ± 10 %, UL: NEC Class 2
Power consumption	< 0.3 W
Sensor measurement range	3 to 45 mm (Stroke range valve spindle)
Actual position signal	digital (RS485)
Ambient temperature	-25 to +80 °C
Protection class	3 acc. to VDE 0580
Type of protection	IP65 and IP67 acc. to EN 60529, Type 4X
Type of Ignition protection	II 3D Ex to IIC T135 °C Dc II 3G Ex nA IIC T4 Gc
Conformity	EMC directive 2004/108/EC
Approvals	cCSAus, cULus Certificate no. 238179

Technical data - rotative Remote Position Sensor (NAMUR)	
Electrical connection	2 m round cable (shielded)
Operating voltage	10 to 30 V DC
Power consumption	< 0.8W
Sensor measurement range	0° to 360°
Actual position signal	digital (RS485)
Ambient temperature	-25 to +80°C
Protection class	3 acc. to VDE 0580
Type of protection	IP65 acc.to EN 60529
Conformity	EMC directive 2004/108/EC
Approvals	UL (cULus) Certificate no. E226909

Technical data - Position feedback with proximity switches (Accessory)	
Electrical connection	M12, 4-pin
Output function	3-wire, normally open contact, PNP
Operating voltage	10 to 30 V DC
Residual ripple	≤ 10% U _{ss}
DC rated current	≤ 100 mA
Type of protection	IP65 and IP67
Protection class	3 acc. to VDE 0580
Conformity	EMC directive 2004/108/EC
Approvals	cCSAus

Note: The position feedback has two proximity switches which are independently adjustable via switch lugs.

Using a remote positioner the length of the control air pipes influences the dynamics and attainable accuracy of the position control loop. The length of the control air pipes therefore should be as short as possible.

Example of assembly variations of Positioner SideControl

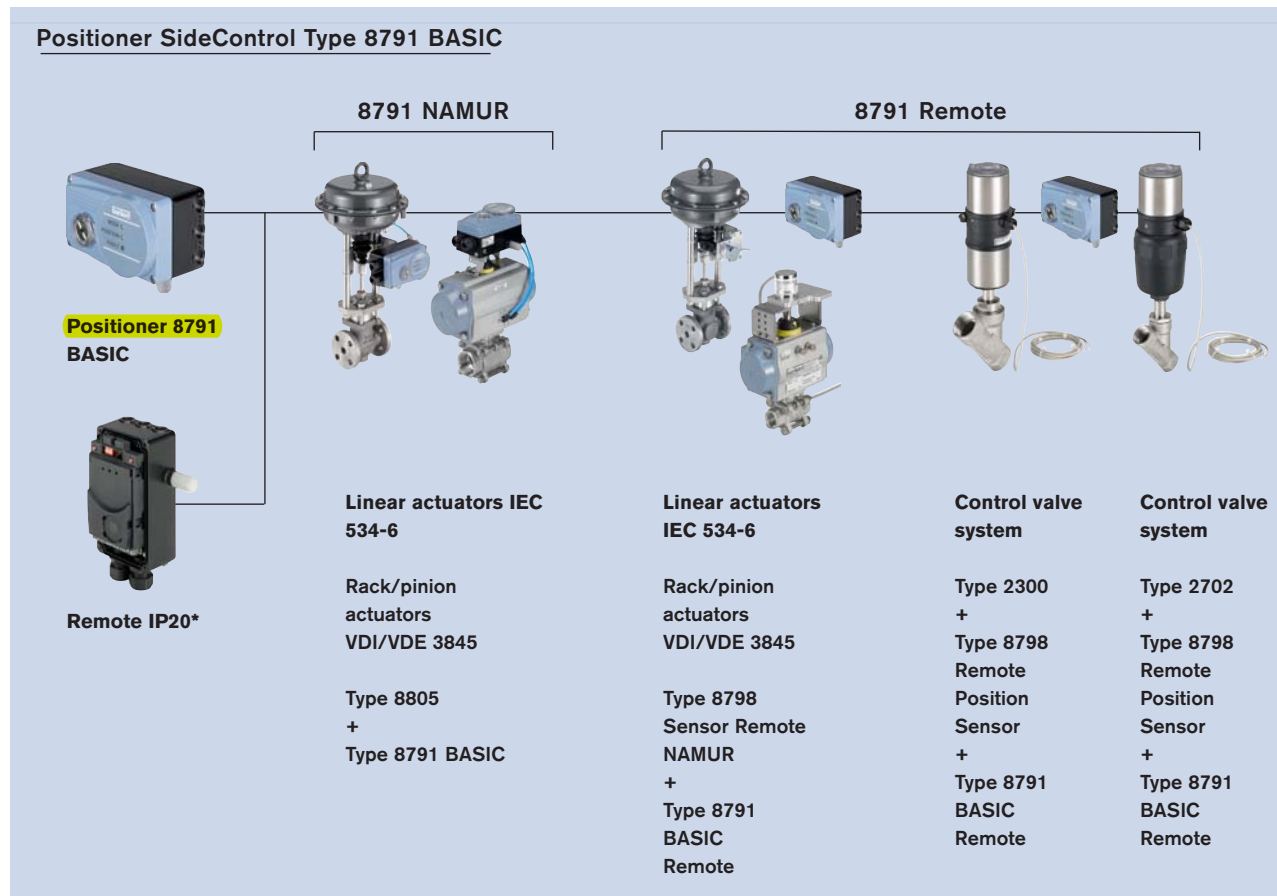

* **Note:** Remote IP20 version exclusively for cabinet mounting

Assembly options

NAMUR Version

(Positioner with integrated position sensor, assembly acc. to NAMUR/IEC 534-6 and VDI/VDE 3845)

Assembly on rotary actuator



Description	Item no.
Adapter kit	787 338
Assembly bridge	770 294

Assembly on linear actuator

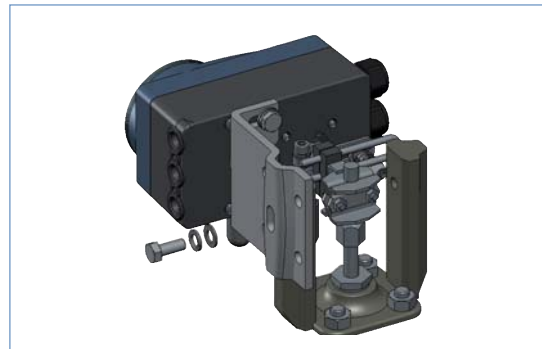

Description	Item no.
Adapter kit	787 215

Dimensions [mm]

Adapter kit

Assembly bridge

Actuator shaft height	A	B	C
20	46.5	80	-
30	56.5	80	130
50	76.5	-	130

Position feedback with proximity switches
(upgrade feature for SideControl BASIC)

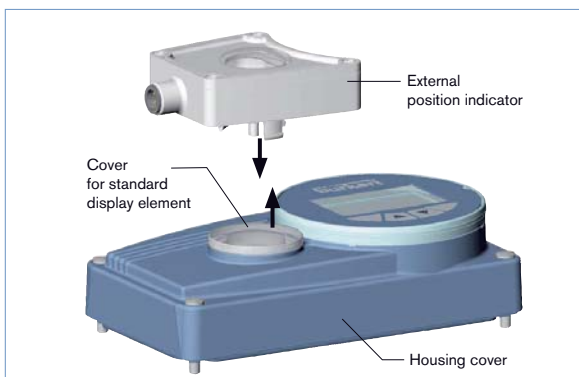

Description	Item no.
Position feedback	677 218

Assembly options *continued*

Remote version

(Remote positioner from actuator with displacement position)

Assembly with accessory brackets



Description	Item no.
Assembly bracket for wall mounting	675 715

Dimensions [mm]

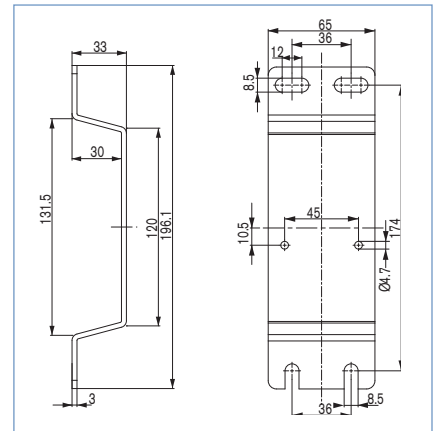

Assembly on DIN-Rail



The adapter can be turned every 90° on the DIN-Rail

Description	Item no.
DIN rail assembly kit	675 702

Dimensions [mm]

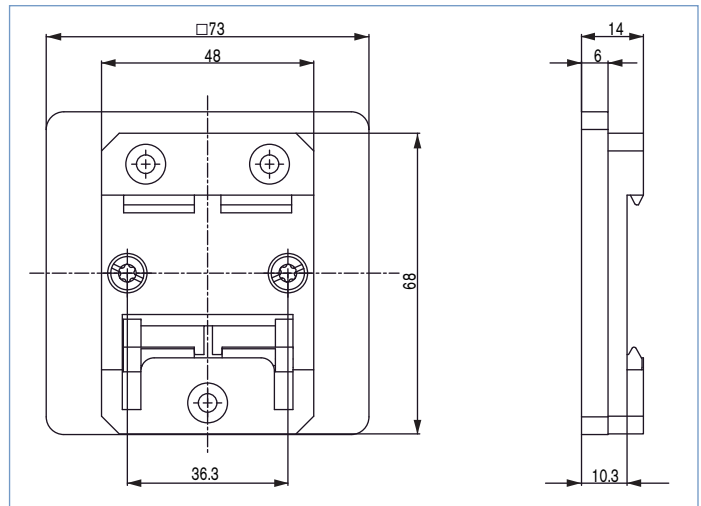

Assembly options *continued*

Remote version

(Remote positioner from actuator with displacement position sensor)

Type 8798



Description	Item no.	
	Standard	ATEX II 3 GD
Remote Position Sensor		
Control valves CLASSIC Types 27xx	211 535	226 859
Control valves ELEMENT Types 23xx	212 360	226 860



Description	Item no.
Remote Position Sensor NAMUR	211 536

Dimensions

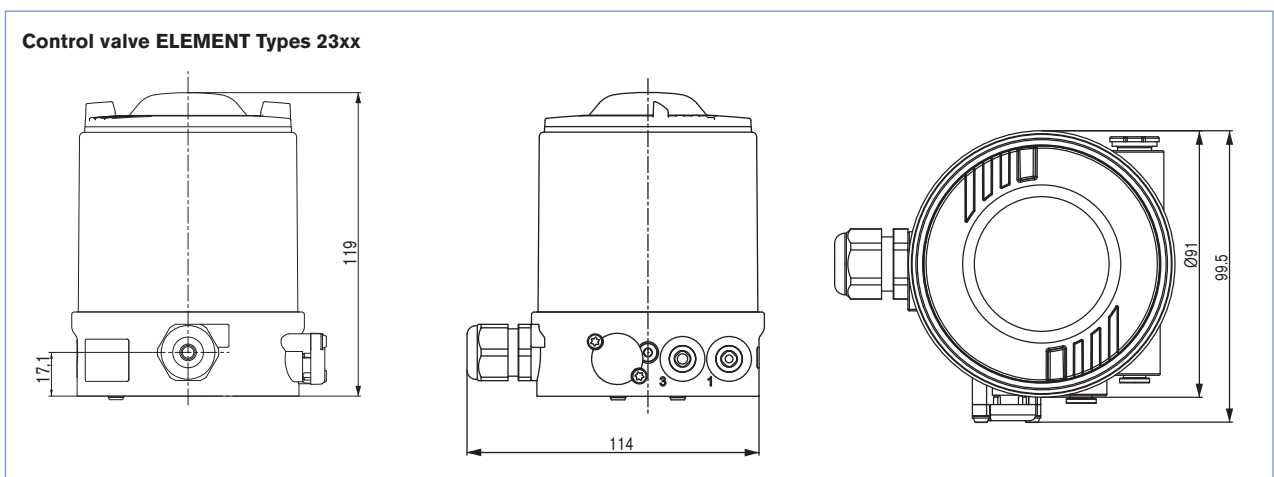
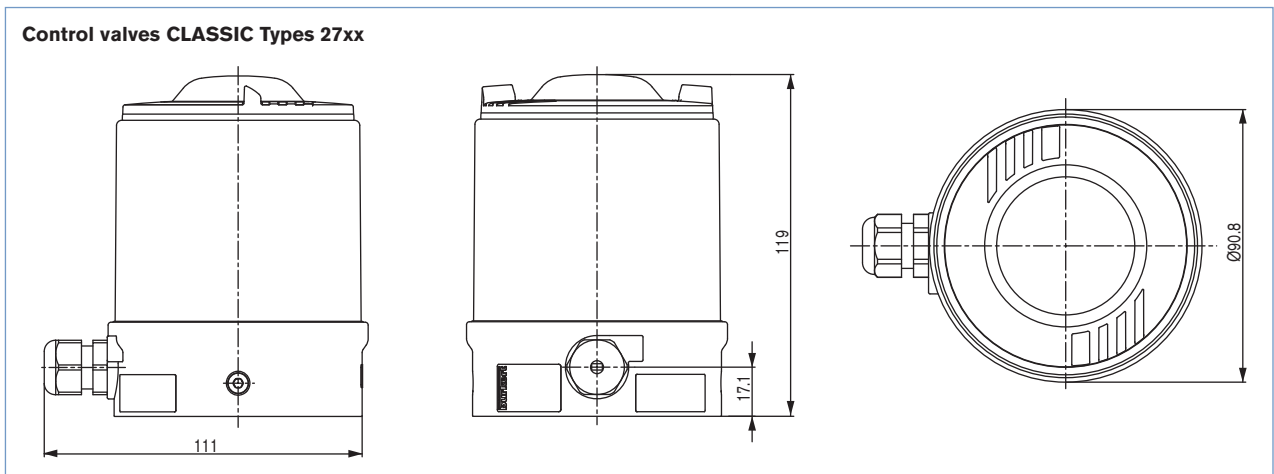

Dimensions

Mounting on control valves according to NAMUR (IEC 534-6 / VDI / VDE 3845)

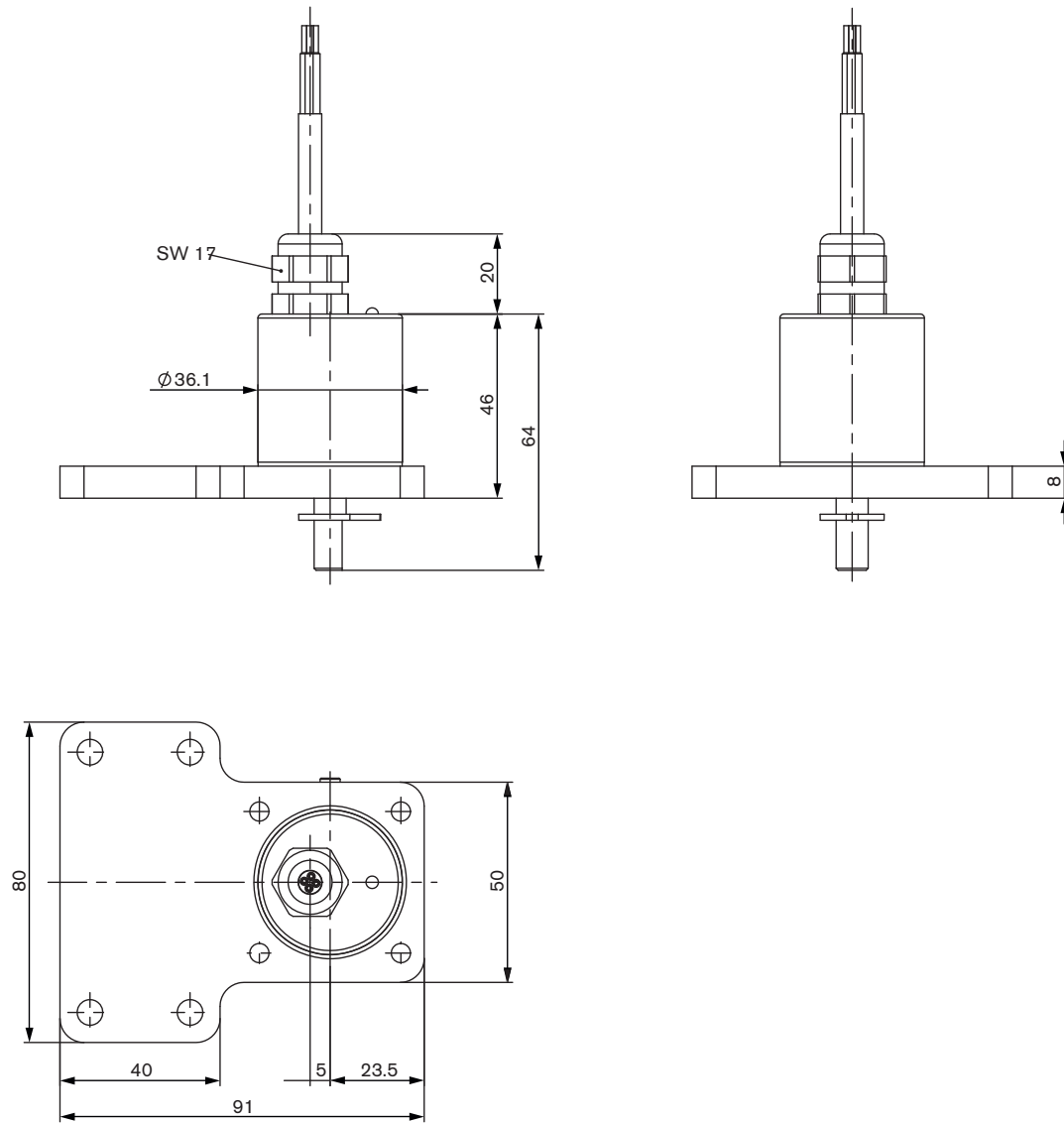

Ordering Chart (further version on request)

Positioner SideControl Basic Type 8791

Assembly variations	Control function	Pilot valve system / Air capacity	Communication	Electrical connection	Binary input	Analogue feedback	ATEX II 3 GD	Item No.
NAMUR IEC 534-6 VDI/VDE 3845	single and double-acting	universal	no	Cable gland	yes	no		211 521
					yes	yes		211 522
					yes	no	yes	226 834
					yes	yes	yes	226 835
				Multipole	yes	no		211 523
					yes	yes		211 524
					yes	no	yes	226 836
					yes	yes	yes	226 837
					no	yes/16 bit		239 617
					no	yes/16 bit	yes	239 618

Assembly variations	Actuator size	Control function	Pilot valve system / Air capacity	Communication	Electrical connection	Binary input	Analogue feedback	ATEX II 3 GD	Item No.
Remote	ELEMENT 70/90 CLASSIC 80/100	single-acting	low	no	Cable gland	yes	no		224 868
		yes	yes				224 869		
	ELEMENT 130 CLASSIC 125-225	single and double-acting	universal			yes	no		211 531
yes		yes				211 532			
Remote IP20	ELEMENT 70/90 CLASSIC 80/100	single-acting	low			yes	no		234 576
		yes	yes				234 578		
	ELEMENT 130 CLASSIC 125-225	single and double-acting	universal			yes	no		211 533
		yes	yes				211 534		

Assembly variations	Electrical connection	Item No.	
Remote Position Sensor		Standard	ATEX II 3 GD
CLASSIC Type 27xx	Cable gland - 10 m round cable	211 535	226 859
ELEMENT Type 23xx	Cable gland - 10 m round cable	212 360	226 860
NAMUR (rotative)	Cable gland - 2 m round cable (max. extension 10 m)	211 536	

i Further versions on request

Positioner BASIC Remote IP20 with actual value for potentiometer signal



Approvals

Protection type: NEMA 4x
Remote Sensor ATEX Cat. 3

Ordering chart for accessories

Description	Item no.
Accessories for SideControl BASIC NAMUR	
Assembly bridge VDI/VDE 3845, stainless steel	770 294
Adapter kit VDI/VDE 3845, stainless steel	787 338
Adapter kit linear actuators IEC 534-6, stainless steel	787 215
Position feedback with proximity switches (optional upgrade feature) ³⁾	677 218

Accessories for SideControl BASIC Remote	
Bracket for wall mounting, stainless steel	675 715
DIN rail assembly kit, Aluminium/stainless steel	675 702
Adapter kit - remote sensor, ELEMENT Type 23xx control valves Actuator size Ø 70/90/130 mm	679 917
Adapter kit - remote sensor, CLASSIC Type 27xx control valves Actuator size Ø 80 mm	679 943
Actuator size Ø 100/125 mm	679 944
Actuator size Ø 175/225 mm	679 945
Sensor Puck (replacement part)	682 240

Standard Accessories	
USB Interface for serial communication	227 093
M12 socket, 8-pin, 2m assembled cable	919 061
M12 socket, 8-pin, 5m assembled cable	919 267
Silencer G 1/4" (spare part)	780 780

* Related Communication software can be downloaded from www.buerkert.com (8791)

³⁾ External end position feedback for upgrading SideControl NAMUR

Connection options

Cable gland connection

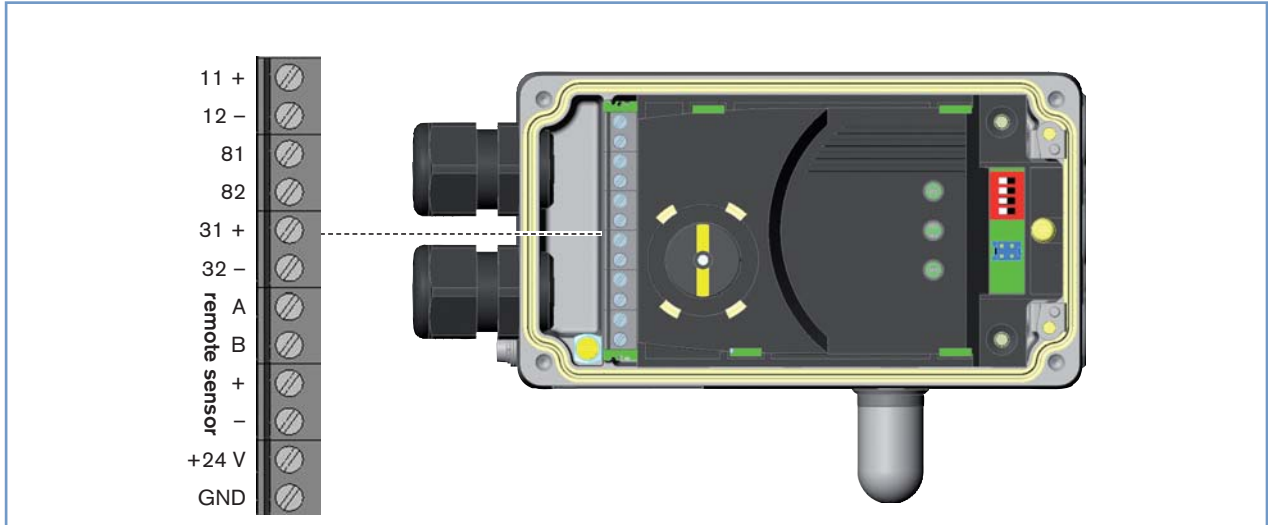

Input signal

Terminal	Configuration	External Circuitry / signal level
11 +	Setpoint +	11 + + (0/4 ... 20 mA) not galvanically isolated
12 -	Setpoint GND	12 - GND
81 +	Binary input +	81 + + 0 ... 5 V (log. 0) 10 ... 30 V (log. 1)
82 -	Binary input -	82 - GND
+24 V	Operating voltages +	+24 V 24 V DC ± 10 % max. residual ripple 10 %
GND	Operating voltages GND	GND

Output signal with optional analogue position feedback

Terminal	Configuration	External Circuitry / signal level
31 +	Analogue feedback +	31 + + (0/4 ... 20 mA) not galvanically isolated
32 -	Analogue feedback GND	32 - GND

Optional remote version in connection with remote positioner sensor Type 8798

Terminal	Configuration	External Circuitry / signal level
S +	Supply sensor +	S + +
S -	Supply sensor -	S - -
A	Serial Interface, A cable	A A line
B	Serial Interface, B cable	B B line

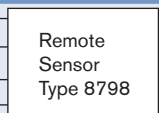

Remote sensor Type 8798

Terminal	Wire colour for cable type		Configuration	External Circuitry
	1	2		
1	white	black	Supply Sensor -	1 8791 or
2	brown		Supply Sensor +	2 8792 / 8793
3	yellow	orange	Serial Interface, B line	3 8791 or
4	green	red	Serial Interface, A line	4 8792 / 8793

Connection options, *continued*

Multi-pin connection

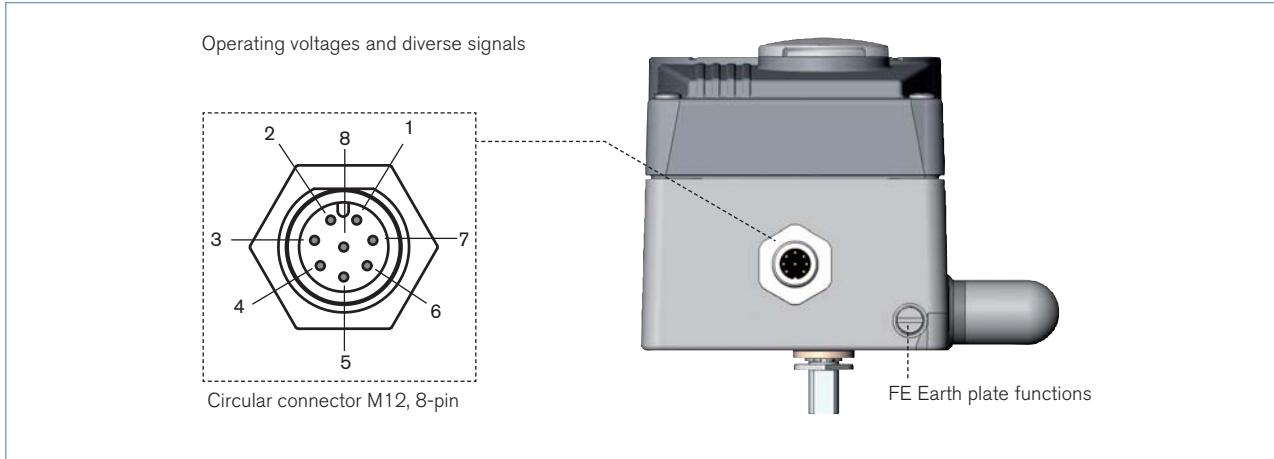

Circular connector M12 - 8-pin (Input signal)

Pin	Wire colours*	Configuration	External Circuitry / signal level
1	white	Setpoint + (0/4-20 mA)	1 + (0/4 -20 mA) not galvanically isolated
2	brown	Setpoint GND	2 GND
5	grey	Binary Output	5 + 0-5 V (log. 0) 10-30 V (log. 1) obtained on Pin 3 (GND)
3	green	GND	3
4	yellow	+ 24 V	4 24 V DC ± 10% max. Residual ripple 10%

Circular connector M12 - 8-pin (analogue position feedback)

8	red	Analogue feedback +	8 + (0/4 -20 mA) not galvanically isolated
7	blue	Analogue feedback GND	7 GND

* The indicated wire colours refer to the connection cable, part no. 919061, available as an accessory

Connection options, *continued*

Electrical connection ASI M12 4-pin

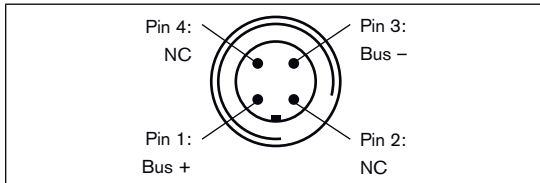

Bus connection without external supply voltage

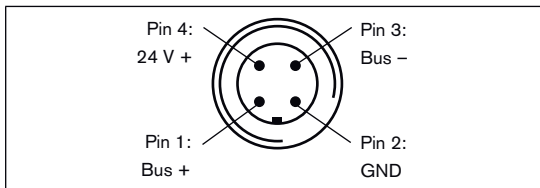

Bus connection with external supply voltage (optional)



Bus connection without external / with external supply voltage

Pin	Designation	Configuration
1	Bus +	AS Interface bus line +
2	NC or GND (optional)	not used or external supply voltage - (optional)
3	Bus -	AS Interface bus line -
4	NC or 24 V + (optional)	not used or external supply voltage + (optional)

Electrical connection Position feedback with proximity switches (accessory for upgrading)

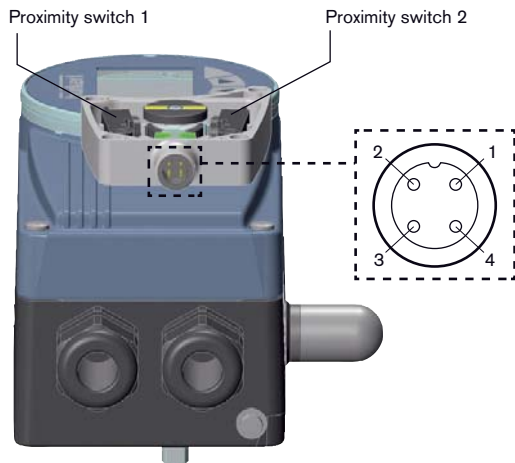

Pin Config.	External circuit /signal level
1 Supply 10 ... 30 V	+10 V ... +30 V — 1 10 ... 30 V
2 Switching output (NO) Proximity switch 1	+10 V ... +30 V — 2 Open / 10 ... 30 V
3 GND	GND — 3 GND
4 Switching output (NO) Proximity switch 2	+10 V ... +30 V — 4 Open / 10 ... 30 V

Signal flow plan

Position control loop

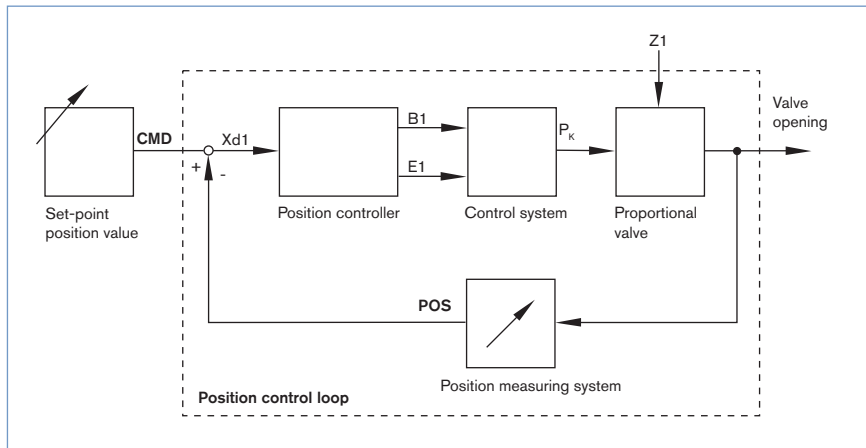

SideControl BASIC functions

- Automatic start of the control system
- Binary input (safety position)
- Analogue position feedback (optional)

DIP-Switch activated device

- Close tight function
- Inversion of the operating direction of the setpoint signal
- Linear characteristic curves selection or customised programming (software interface)
- Manual and automatic operation

Communications software with activatable and parameter driven functions

- Customised programming transmission characteristics
- Choices of setpoint signal
- Range splitting setpoint signal
- Limitation of valve stroke
- Limitation of operation speed
- Definition of the safety position
- Signal failure detection

Schematic diagram of SideControl Type 8791 BASIC

without fieldbus interface

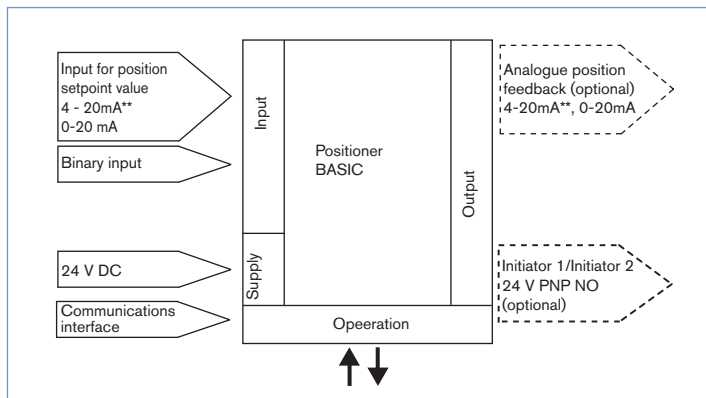

**Default setting

with AS-interface

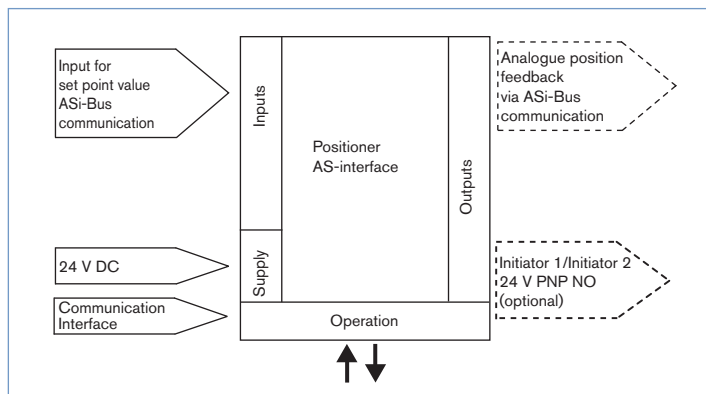

Dimensions [mm]

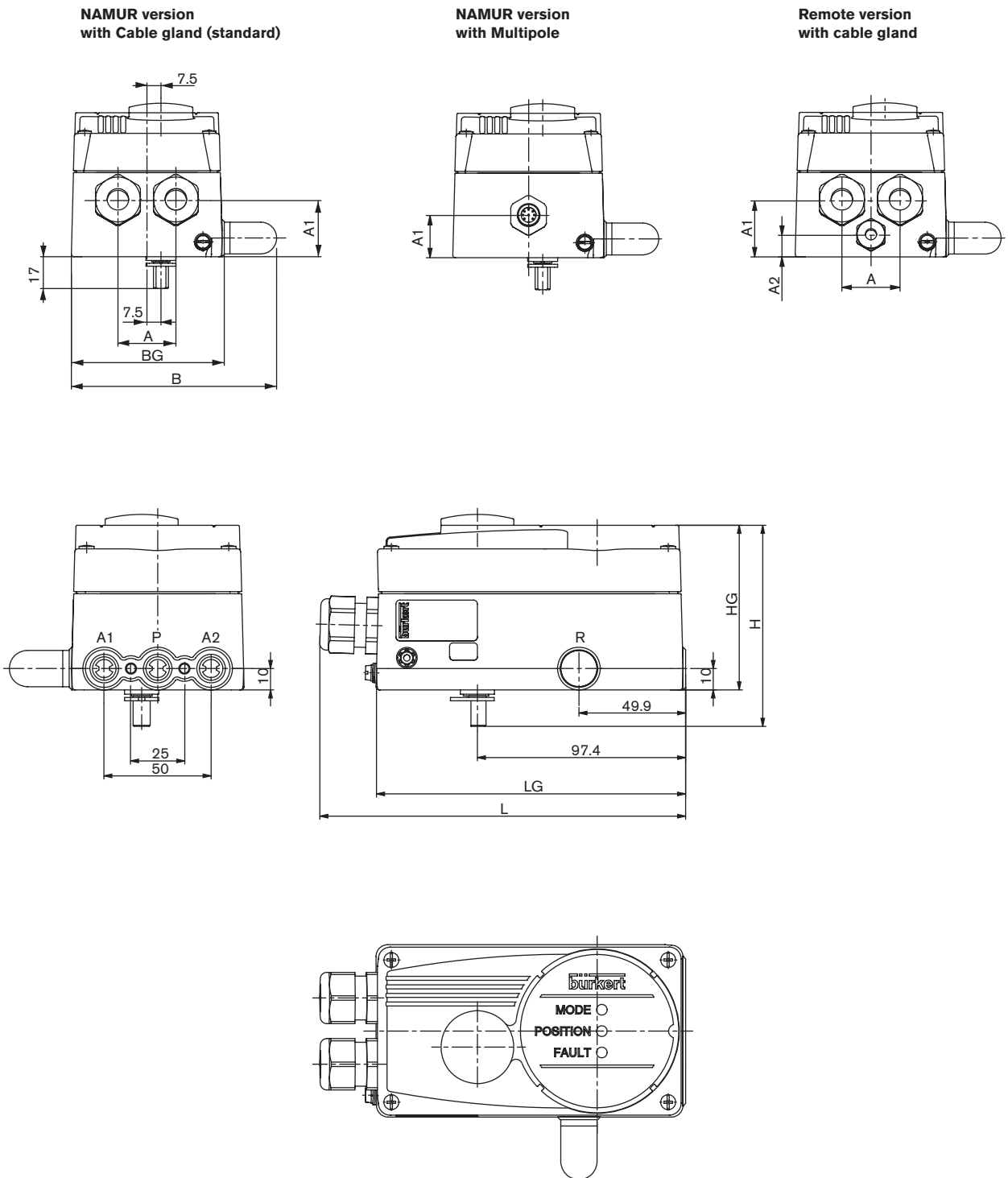

Description	LG	L	BG	B	HG	H	A	A1	A1
Standard	144.6	171.1	81.8	109.8	77	94.1	31	30	-
Remote	144.6	171.1	81.8	109.8	77	94.1	31	30	11.5
Multipole	144.6	171.1	81.8	109.8	77	94.1	-	22.5	-
Remote IP20	144.6	171.1	81.8	109.8	67	-	31	30	11.5

Dimensions [mm], continued

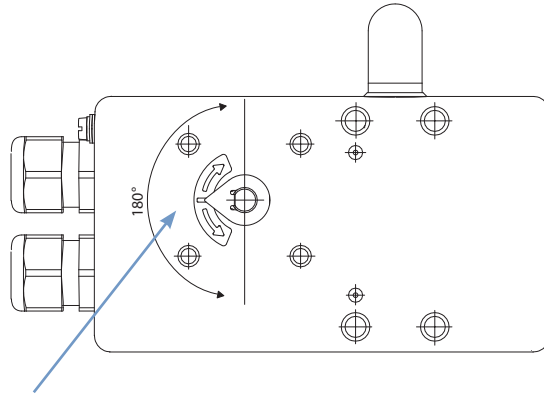

The rotation angle of the sensor must be within a range of 180°

With the valve open approx. 50%, the sensor indicator should be in this position.

NAMUR Version

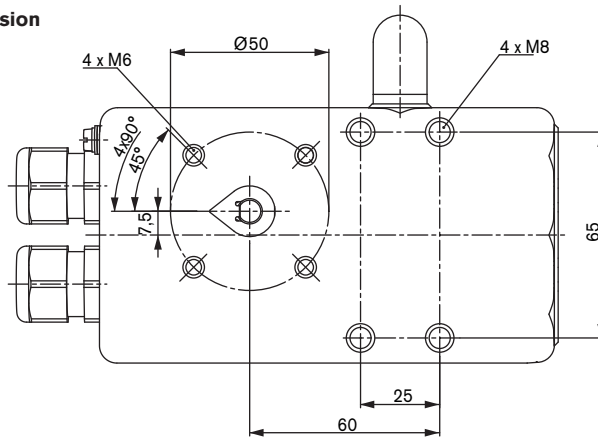

Remote version

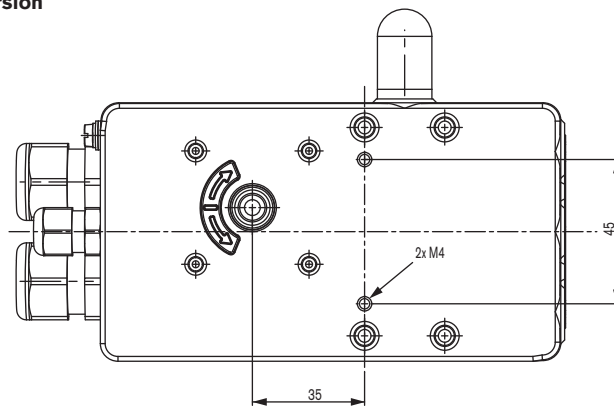

DTS 1000123308 EN Version: E Status: RL (released | freigegeben | valide) printed: 18.03.2015

To find your nearest Bürkert facility, click on the orange box → www.burkert.com

In case of special application conditions,
please consult for advice

Subject to alterations.
© Christian Bürkert GmbH & Co. KG

1501/5_EU-en_00895131