



ART. 037016 TIS1

MANICOTTO ELETTROSALDABILE, PE 100, SDR 17

ELECTROFUSION COUPLER, PE 100, SDR 17

APPLICAZIONE:

Impianti di acquedottistica, di convogliamento gas combustibili, di fognature civili ed industriali, di irrigazione etc...

APPLICATION:

Water pipeline systems, for gas, civil and industrial sewerage, irrigation etc...

CARATTERISTICHE PRINCIPALI - MAIN FEATURES

NORME PRODOTTO:	UNI EN 1555-3 UNI EN 12201-3 UNI EN ISO 15494	PRODUCT STANDARS:	UNI EN 1555-3 UNI EN 12201-3 UNI EN ISO 15494
MASSIMA PRESSIONE DI ESERCIZIO AMMESSA:	Acqua 10 bar Gas 3 bar	MAXIMUM OPERATING PRESSURE:	Water 10 bar Gas 3 bar
TEMPERATURA DI ESERCIZIO:	Max. +60°C	WORKING TEMPERATURE:	Max. +60°C
RAPPORTO PRESSIONE / TEMPERATURA	Conforme con UNI EN 1555-3 - UNI EN 12201-3	PRESSURE / TEMPERATURE RATING	According to UNI EN 1555-3 - UNI EN 12201-3

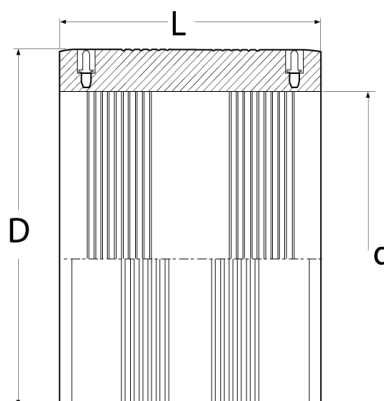

d	D	L	kg
280	330	220	5.00
315	365	230	7.05
355	415	255	10.31
400	470	300	14.50
450	530	320	20.75
500	590	365	27.00
560	655	400	36.50
630	740	420	50.00

d	D	L	kg
710	840	445	66.50
800	935	470	86.30
900	1050	500	114.00
1000	1175	500	147.50
1200	1371	500	170.50
1400	1600	550	225.30
1600	1829	575	348.00
2000	2286	575	527.00