

FILTR / OSADNIK SKOŚNY "Y" KOŁNIERZOWY PN16 Z POWŁOKĄ EPOKSYDOWĄ "Y" TYPE STRAINER PN16 EPOXY COATING

ZASTOSOWANIE:

Dostawa, odbiór, dystrybucja wody, gospodarka ścieków.

APPLICATION:

Supply, collection, distribution of water, networks for the collection and discharge of waste water.

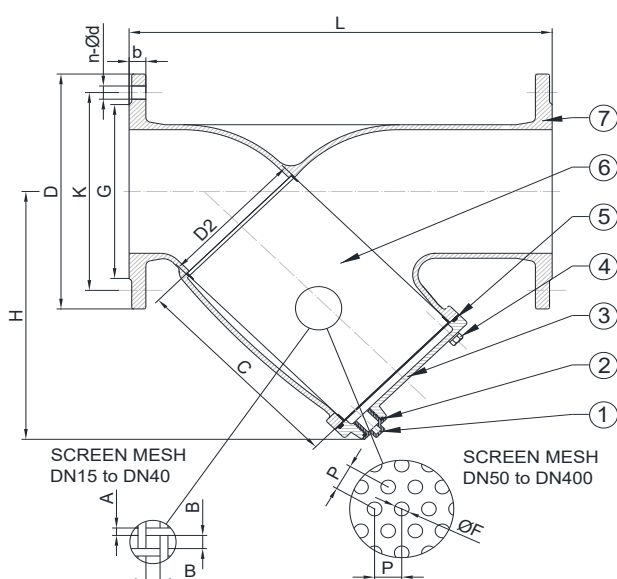

POWŁOKA ANTYKOROZYJNA - COATING

Zewnętrzna / wewnętrzna powłoka epoksydowa w kolorze niebieskim RAL 5015 o grubości 250µm.

External / internal FBE coating process with epoxy resin powder of blue colour RAL 5015 and thickness of 250µm.

CECHY PRODUKTU - MAIN FEATURES

DŁUGOŚĆ ZABUDOWY:	EN 558 Szereg 1
KOŁNIERZE:	EN 1092-2
PRÓBY:	EN 12266-1
TEMPERATURA ROBOCZA:	Max. +70°C
FACE TO FACE:	EN 558 Serie 1
FLANGES:	EN 1092-2
TESTS:	EN 12266-1
WORKING TEMPERATURE:	Max. +70°C

	CZĘŚCI - PARTS	MATERIAŁY - MATERIALS
1	KOREK SPUSTOWY DRAIN PLUG	STAL NIERDZEWNA A2-70 A2-70 STAINLESS STEEL
2	O-RING O-RING	EPDM EPDM
3	POKRYWA COVER	EN-GJS 500-7 (GGG-50) EN-GJS 500-7 (GGG-50)
4	ŚRUBA FASTENERS	STAL NIERDZEWNA A2-70 A2-70 STAINLESS STEEL
5	USZCZELKA GASKET	EPDM EPDM
6	WKŁAD FILTRA SCREEN	AISI 304 (EN 1.4301) SS AISI 304 (EN 1.4301)
7	KORPUS BODY	EN-GJS 500-7 (GGG-50) EN-GJS 500-7 (GGG-50)

DN	15	20	25	32	40	50	65	80	100	125	150	200	250	300	350	400
L	130	150	160	180	200	230	290	310	350	400	480	600	730	850	980	1100
H	78.5	84.5	87.5	105	108	135	160	184	211	262	301	370	486	582	650	714
D	95	105	115	140	150	165	185	200	220	250	285	340	405	460	520	580
K	65	75	85	100	110	125	145	160	180	210	240	295	355	410	470	525
G	46	56	65	76	84	99	118	132	156	184	211	266	319	370	429	480
b	14	16	16	18	19	19	19	19	19	19	19	20	22	24,5	26,5	28
n-Ød	4-14	4-14	4-14	4-19	4-19	4-19	4-19	8-19	8-19	8-19	8-23	12-23	12-28	12-28	16-28	16-31
A	Ø0.4	Ø0.4	Ø0.4	Ø0.4	Ø0.4	-	-	-	-	-	-	-	-	-	-	-
B	0.7	0.7	0.7	0.7	0.7	-	-	-	-	-	-	-	-	-	-	-
ØF	-	-	-	-	-	2.0	2.0	2.0	2.0	2.0	3.0	3.0	3.0	3.0	3.0	3.0
P	-	-	-	-	-	3.7	3.7	3.7	3.7	3.7	5	5	5	5	5	5
BSP	NA	NA	1/2"	1/2"	1/2"	1/2"	1/2"	1/2"	3/4"	3/4"	3/4"	3/4"	3/4"	3/4"	1"	1"
C	59	65	68	89	89	116	145	158	183	239	252	281	427	503	554	602
D2	22	27	32	39	47	55	77	87	109	139	169	209	268	318	368	418
W (kg)	2.2	2.5	4.0	4.5	6.0	7.6	10.6	12.0	16.0	25.5	33.0	60.5	93.0	135	213	260