

**PRZEPUSTNICA KOŁNIERZOWA PODWÓJNIE MIMOŚRODOWA PN10-PN16  
Z DYSKIEM ZE STALI NIERDZEWNEJ**

**DOUBLE FLANGED DOUBLE ECCENTRIC BUTTERFLY VALVE PN10-PN16  
WITH STAINLESS STEEL DISC**

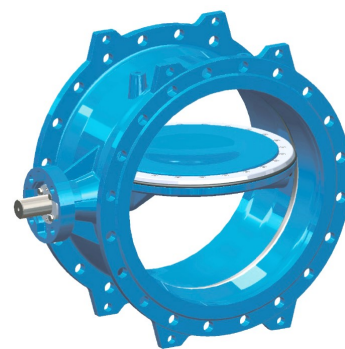

**ZASTOSOWANIE:**

Dostawa, odbiór i dystrybucja wody.

**APPLICATION:**

Supply, collection and distribution of water.

CHECHY PRODUKTU - MAIN FEATURES

<b>WYKONANIE:</b>	EN 593, EN 1563, EN 1074-1, EN 1074-2
<b>DŁUGOŚĆ ZABUDOWY:</b>	EN 558 Szereg 14
<b>KOŁNIERZE:</b>	EN 1092-2
<b>KOŁNIERZ POD NAPĘD:</b>	ISO 5211
<b>PRÓBY:</b>	EN 12266-1
<b>SZCZELNOŚĆ ZAMKNIĘCIA:</b>	Klasa A w obu kierunkach przepływu (zerowy przeciek)
<b>TEMPERATURA ROBOCZA:</b>	Min. -10°C Max. +70°C
<b>DESIGN STANDARD:</b>	EN 593, EN 1563, EN 1074-1, EN 1074-2
<b>FACE TO FACE:</b>	EN 558 Series14
<b>FLANGES:</b>	EN 1092-2
<b>TOP FLANGE:</b>	ISO 5211
<b>TESTS:</b>	EN 12266-1
<b>LEAKAGE RATE:</b>	Rate A in both flow directions (zero drops)
<b>WORKING TEMPERATURE:</b>	Min. -10°C Max. +70°C

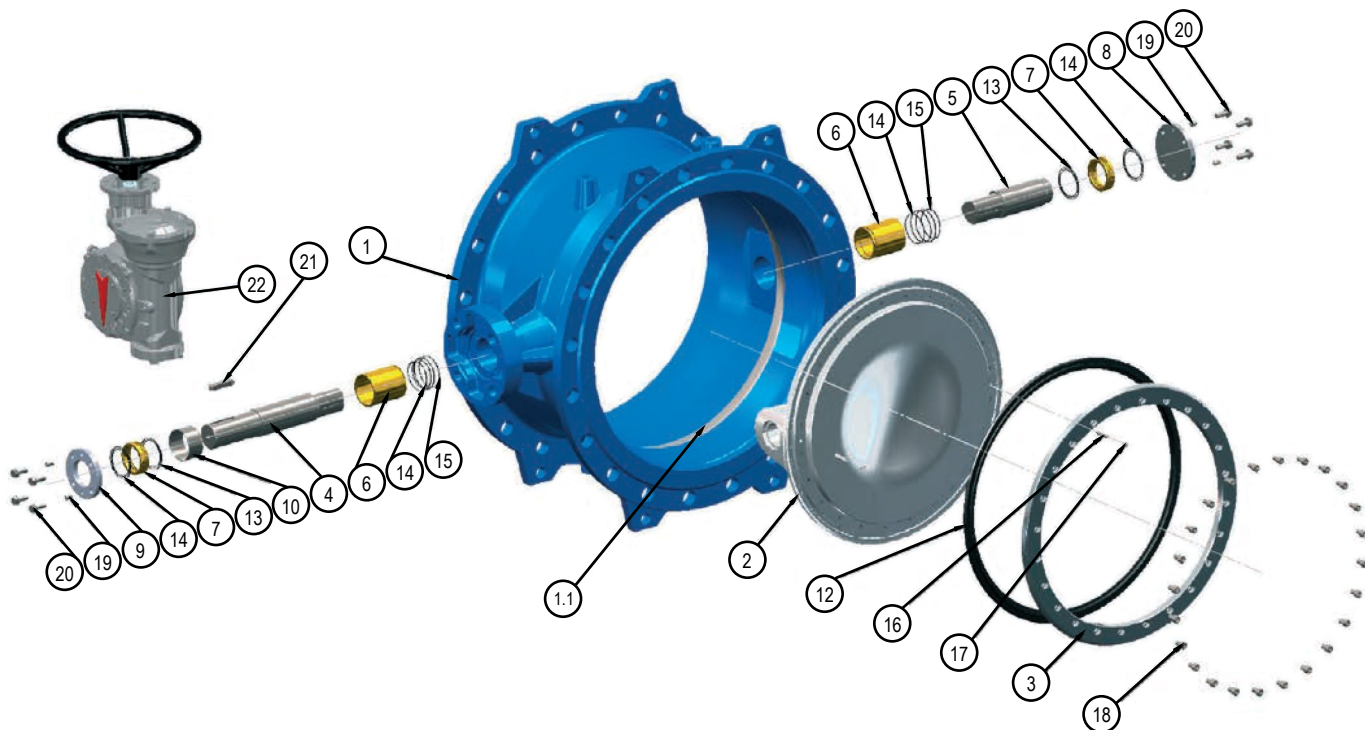

POWŁOKA ANTYKOROZYJNA - COATING

Wewnętrzna i zewnętrzna powłoka epoksydowa (FBE) w kolorze niebieskim RAL 5015 o grubości min. 300 µm.

Internal and external surface protection made of epoxy resin powder (FBE) in blue colour RAL 5015 and thickness min. 300 µm.

	CZĘŚCI - PARTS	MATERIAŁY - MATERIALS
1	KORPUS BODY	EN-GJS-400-15 (GGG-40) EN-GJS-400-15 (GGG-40)
1.1	SIEDZISKO (GNAZDO) BODY SEAT RING	EN 1.4404 (AISI 316L) EN 1.4404 (AISI 316L)
2	DYSK DISC	EN 1.4408 (AISI 316 / CF8M) EN 1.4408 (AISI 316 / CF8M)
3	PIERŚCIEŃ DOCISKAJĄCY USZCZELKĘ DYSKU RETAINING SEAL RING	EN 1.4301 (AISI 304) / EN 1.4571 (AISI 316Ti) / EN 1.4462 (DUPLEX) EN 1.4301 (AISI 304) / EN 1.4571 (AISI 316Ti) / EN 1.4462 (DUPLEX)
4	WAŁ NAPĘDU DRIVEN SHAFT	EN 1.4021 (AISI 420) / EN 1.4301 (AISI 304) / EN 1.4401 (AISI 316) / EN 1.4462 (DUPLEX) EN 1.4021 (AISI 420) / EN 1.4301 (AISI 304) / EN 1.4401 (AISI 316) / EN 1.4462 (DUPLEX)
5	WOLNY WAŁ SHAFT (FREE END)	EN 1.4021 (AISI 420) / EN 1.4301 (AISI 304) / EN 1.4401 (AISI 316) / EN 1.4462 (DUPLEX) EN 1.4021 (AISI 420) / EN 1.4301 (AISI 304) / EN 1.4401 (AISI 316) / EN 1.4462 (DUPLEX)
6	TULEJA ŁOŻYSKOWA BEARING BUSH	ALU-BRAZ ALUMINIUM BRONZE
7	TULEJA USZCZELNIAJĄCA SEALING BUSH	ALU-BRAZ ALUMINIUM BRONZE
8	POKRYWA COVER	EN 1.4401 (AISI 316) EN 1.4401 (AISI 316)
9	KOŁNIERZ TULEJI USZCZELNIAJĄCEJ SEALING BUSH FLANGE	EN 1.4401 (AISI 316) EN 1.4401 (AISI 316)
10	TULEJA DYSTANSOWA SPACER	EN 1.4401 (AISI 316) EN 1.4401 (AISI 316)
12	PIERŚCIEŃ USZCZELNIAJĄCY DYSK DISC SEALING RING	EPDM EPDM
13	O-RING O-RING	EPDM EPDM
14	O-RING O-RING	EPDM EPDM
15	O-RING O-RING	EPDM EPDM
16	SWORZEŃ ZABEZPIEZAJĄCY SAFETY PIN	STAL NIERDZEWNA STAINLESS STEEL
17	ŚRUBA DOCISKOWA GRUB SCREW	STAL NIERDZEWNA A2-70 / A4-70 STAINLESS STEEL A2-70 / A4-70
18	ŚRUBY MOCUJĄCE PIERŚCIEŃ DOCISKOWY RETAINING RING SCREW	STAL NIERDZEWNA A2-70 / A4-70 STAINLESS STEEL A2-70 / A4-70
19	ŚRUBA DOCISKOWA GRUB SCREW	STAL NIERDZEWNA A2-70 / A4-70 STAINLESS STEEL A2-70 / A4-70
20	ŚRUBY I PODKŁADKI SCREW AND WASHER	STAL NIERDZEWNA A2-70 / A4-70 STAINLESS STEEL A2-70 / A4-70
21	KLIN PARALLEL KEY	STAL STEEL
22	PRZEKŁADNIA GEARBOX	ZGODNIE ZE SPECYFIKACJĄ PRODUCENTA ACCORDING TO MANUFACTURER SPECIFICATION

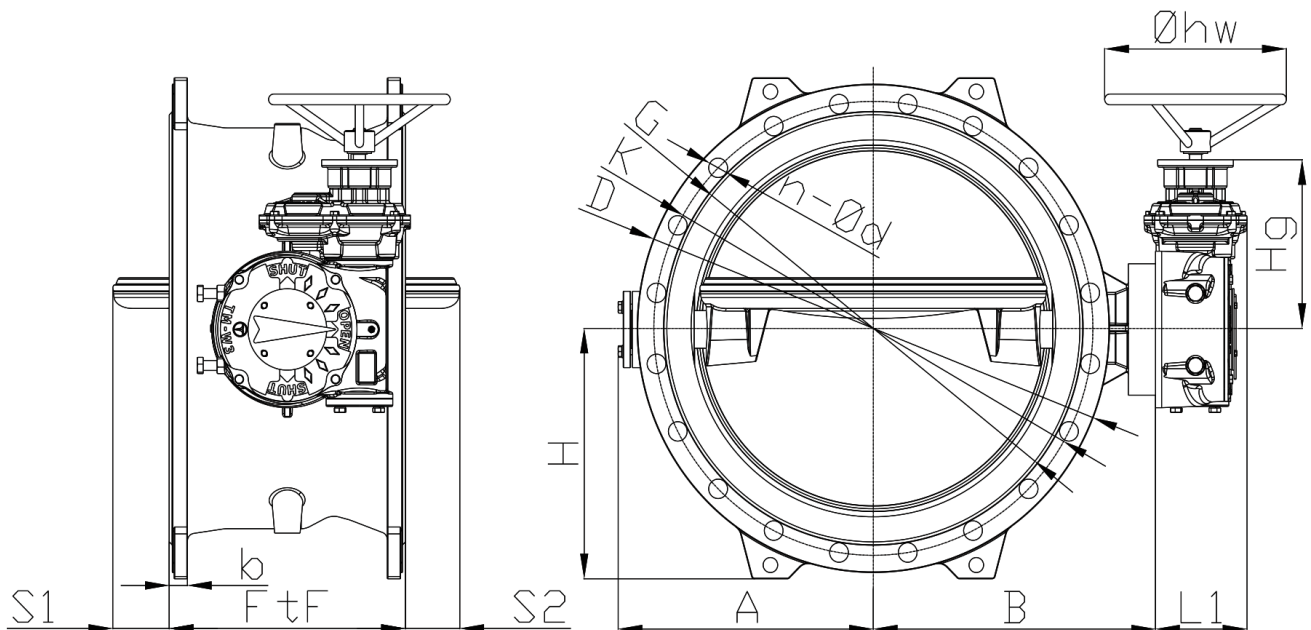

PN10														
DN	G	K	D	n-ød	b	FtF	A	B	L1	H	Hg	S1-S2	øhw	W (kg)
200	266	295	340	8-23	20	230	185	218	91	180	133	-	300	51
250	319	350	395	12-23	22	250	209	242	91	210	133	-	300	63
300	370	400	445	12-23	24.5	270	240	268	114,5	235	186	15	300	82
350	429	460	505	16-23	24.5	290	263	291	114,5	262	186	30	300	112
400	480	515	565	16-28	24.5	310	298	336	123	288	210	40	300	146
450	530	565	615	20-28	25.5	330	325	363	149	312	251	55	300	185
500	582	620	670	20-28	26.5	350	348	386	149	342	251	70	300	216
600	682	725	780	20-31	30	390	422	466	149	400	263,5	95	300	333
700	794	840	895	24-31	32.5	430	482	530	200	460	315	130	400	515
800	901	950	1015	24-34	35	470	541	617	215	520	347,5	160	400	696
900	1001	1050	1115	28-37	37.5	510	614	673	215	568	347,5	190	400	942
1000	1112	1160	1230	28-37	40	550	675	721	215	625	347,5	215	400	1151
1100	1218	1270	1340	32-37	42.5	590	742	784	268	695	412	250	400	1565
1200	1328	1380	1455	32-41	45	630	798	868	268	738	412	275	400	1913
1400	1530	1590	1675	36-44	46	710	985	965	280	853	464,5	-	630	3004
1600	1750	1820	1915	40-50	49	790	1115	1110	345,5	973	576,5	-	630	4881
1800	1950	2020	2115	44-50	52	870	1245	1200	345,5	1073	576,5	-	630	5750
2000	2150	2230	2325	48-50	55	950	1495	1487	357	1183	624	-	630	7940

PN16														
DN	G	K	D	n-ød	b	FfF	A	B	L1	H	Hg	S1-S2	øhw	W (kg)
200	266	295	340	12-23	20	230	185	218	91	180	133	-	300	51
250	319	355	405	12-28	22	250	209	242	91	210	133	-	300	63
300	370	410	460	12-28	24.5	270	240	268	114,5	235	186	15	300	82
350	429	470	520	16-28	26.5	290	275	313	123	267	210	30	300	114
400	480	525	580	16-31	28	310	298	336	149	293	251	40	300	172
450	548	585	640	20-31	30	330	336	386	149	324	251	55	300	217
500	609	650	715	20-34	31.5	350	372	420	149	638	263,5	70	300	290
600	720	770	840	20-37	36	390	430	492	200	430	315	95	400	476
700	794	840	910	24-37	39.5	430	497	572	215	470	347,5	130	400	600
800	901	950	1025	24-41	43	470	581	626	215	525	347,5	160	400	795
900	1001	1050	1125	28-41	46.5	510	644	686	268	573	412	190	400	1140
1000	1112	1170	1255	28-44	50	550	701	770	268	636	412	215	400	1451
1100	1218	1270	1355	32-44	53.5	590	792	818	280	696	464,5	250	630	1888
1200	1328	1390	1485	32-50	57	630	849	886	280	750	464,5	275	630	2327
1400	1530	1590	1685	36-50	60	710	992	965	345,5	858	576,5	-	630	3335
1600	1750	1820	1930	40-57	65	790	1136	1110	345,5	980	576,5	-	630	5028
1800	1950	2020	2130	44-57	70	870	1246	1220	356,5	1080	624	-	630	6787
2000	2150	2230	2345	48-62	75	950	1520	1385	357	1188	624	-	630	8940

POLIGONALNE POŁĄCZENIE WAŁU Z DYSKIEM - POLYGONAL SHAFT AND DISC CONNECTION

Poligonalny kształt wału eliminuje konieczność zastosowania sworzni do łączenia z dyskiem.  
 Poligonalna budowa wału zapewnia płynny ruch podczas pracy dysku. Taki kształt eliminuje powstawanie wibracji i zapewnia szczelność zamknięcia.  
 Zamknięte piasty wałów poprawiają odporność na korozję połączenia wału z dyskiem i eliminują również możliwość powstawania ognisk korozji.

The polygonal shape of the shaft eliminates the need for pins to connect to the disc.  
 The polygonal design of the shaft ensures smooth movement during disc operation. This shape eliminates vibrations and ensures tightness of the closure.  
 Closed hub hubs improve the corrosion resistance of the shaft-disc connection and also eliminate the possibility of corrosion centers.



Wał (napędu) dysku o poligonalnym kształcie  
 The polygonal shape of driven shaft

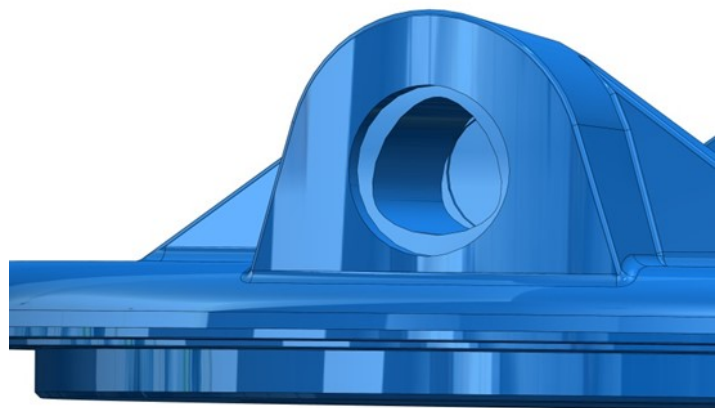

Poligonalny otwór w dysku do połączenia wału (napędu)  
 The polygonal disc hole to driven shaft connection